

**Compliance Status Report up to 30<sup>th</sup> Nov 2021 of Environmental Clearance for Pradhan Mantri Awas Yojana (PMAY) Housing Scheme at Plot no. 2, Sector- 6, near Bamandongri Railway Station, Ulwe Node, Navi Mumbai, Taluka - Panvel, District-Raigad**



# Environment Compliance Report

## SPECIFIC CONDITIONS

1	PP to submit & upload copy of LOI received for proposed project.
2	PP to submit Undertaking from CIDCO regarding nodal STP of CIDCO is sufficing for additional capacity of the project.
3	PP have provisional NOC, PP to submit the CFO NOC
4	PP to submit the sewerage network, water supply, storm water drain NOC from local planning authority
5	PP to submit clear design & permission of storm water drain approved by SWD department of local body
6	PP to incorporate biodiversity mitigation measures suggested in EIA should be incorporated in planning & implement the same.
7	PP to revise the wind analysis considering the stilt also
8	PP to provide more mitigation measures to reduce the heat island effect
9	Committee noted that, as sewer is directly connected to nodal STP, PP i.e., local planning authority (CIDCO) to recycle that sewerage & use treated wastewater for flushing, gardening etc. minimum to 65%
10	PP to provide mitigation measures to reduce noise pollution
11	The PP to get NOC from competent authority with reference to Thane creek flamingo sanctuary if the project site falls within 10 Km radius from the said sanctuary boundary. The planning authority to ensure fulfilment of this condition before granting CC
12	PP to ensure that CER plan gets approved from Municipal Commissioner.
13	PP Shall comply with Standard EC conditions mentioned in the Office Memorandum issued by MoEF& CC vide F.No.22-34/2018-1A.111 dt.04.01 .2019.
14	SEIAA decided to grant EC for FS1:179422.97 m2, Non- FS1:159728.98 m2 and Total BIJA: 339151.95 m2 (Plan Approval no-LOI no CIDCO/SR.Arch(BP-IHP)2019/354, dated- 08.08 2019)

## GENERAL CONDITIONS

Point 1:- E-waste shall be disposed through Authorized vendor as per E-waste (Management and Handling) Rules, 2016

Not Applicable

## GENERAL CONDITIONS

Point 2:- The Occupancy Certificate shall be issued by the Local Planning Authority to the project only after ensuring sustained availability of drinking water, connectivity of sewer line to the project site and proper disposal of treated water as per environmental norms

As of now construction work in progress

## GENERAL CONDITIONS

Point 3:- This environmental clearance is issued subject to obtaining NOC from Forestry & Wildlife angle including clearance from the standing committee of the National Board for Wildlife as if applicable & this environment clearance does not necessarily implies that Forestry & Wild life clearance granted to the project which will be considered separately on merit.

Not Applicable

## GENERAL CONDITIONS

Point 4:- PP has to abide by the conditions stipulated by SEAC& SEIAA.

For Info.

## GENERAL CONDITIONS

Point 5:- The height, Construction built up area of proposed construction shall be in accordance with the existing FSI/FAR norms of the urban local body & it should ensure the same along with survey number before approving layout plan & before according to commencement certificate to proposed work. Plan approving authority should also ensure the zoning missibility for the proposed project as per the approved development plan of the area.

Architect  
Hafeez  
Contractor

Letter No: AHC\_CIDCO\_PKG-IV\_731

Date: 28<sup>th</sup> Feb, 2023

### To Whom It May Concern,

**Subject:** Proposed Mass Housing Scheme on Plot no 02, Sector 06, at Baramandongri Railway station, Ulwe Node, Navi Mumbai for CIDCO LTD. (UNDER PMAY).

**Proposal No.** CIDCO /BP-IHP/2019/131

Ref. No. CIDCO / SR.ARCH.(BP-IHP) / 2019 / 354 Date: 08/08/2019

Dear Sir,

Attached below is the details of Proposed Mass Housing Scheme on Plot no 02, Sector 06, at Baramandongri Railway station, Ulwe Node, Navi Mumbai for the Residential and Comm. Buildings, with reference to LOI letter no CIDCO / SR. ARCH.(BP-IHP)/2019/354.

Preamble of the said proposal is as given below:-

1.	Name of the Owner	Superintendent Engineer (HSG II)
2.	Name of the Developer	CIDCO Ltd.
3.	Property Details	Plot no 02, Sector 06, Baramandongri Railway station, Ulwe Node, Navi Mumbai
4.	Area Statement	
a	Plot area	109265.736 Sq. Mt.
b	Permissible F.S.I.	2.5
c	Permissible BUA	232189.69 Sq. Mt.
e	Earlier approved BUA (F.S.I. Area)	--
f	Now Proposed BUA (F.S.I. Area)	179422.972 Sq. Mt.
g	BUA under free of F.S.I.	159728.984 Sq. Mt.
h	Total Construction Area	339151.956 Sq.Mt.

	Number of Buildings	Type	Nos.	Floors	Height
		EWS-A (R)	43	Gr + 15	49.75 Mtrs.
		Commercial blocks	4	Gr	4.2 Mtrs.
		Community center	2	Gr	5.0 Mtrs.
		Security cabins	6	Gr	2.7 Mtrs.
6.	R.G. Area	17644.12 SQ.M. (16.14 %)			
7.	Permissible Height of Buildings as per Height clearance:	49.78 Mtrs.			
8.	No. Of trees to be Planted	1 tree / 100 Sq.mt of plot area (GDRC) - 1092 No. 1 tree/ 80 Sq.mt of Plot area (MOEF) - 1365 No. Proposed Tree Plantation - 1368 No.			
9.	Number and Area Of Basement.	N.A			
10.	Number and Area Of Podium	N.A			
11.	Right of way (width of the road from nearest fire Station)	30.0m Wide ROW			
12.	Width of all internal road	9.0m, 7.5m and 6m Wide driveway			
13.	Parking	Cars	Required Parking Spaces = 1506 Nos. Proposed Parking Spaces = 1600 Nos.		
		Bikes	Required Parking Spaces = 129 Nos. Proposed Parking Spaces = 150 Nos.		
14.	Tenements	Commercial - 258 Nos. Residential - 5160 Nos.			
15.	commercial	6998.998 Sq. Mt			
16.	Community hall area ( F.S.I.)	800 Sq. Mt			
17.	Security cabin area ( F.S.I.)	48.384 Sq. Mt.			

Thanking you,



Yours faithfully,

Mr. Mayur Sondagar  
Associate Architect

For Architect Hafeez Contractor (CA/77/04043)

Hafeez Contractor  
A I I A, G D Arch  
M S Arch & U D (USA)  
Ph D (Hon)

## GENERAL CONDITIONS

Point 6:- If applicable Consent for Establishment" shall be obtained from Maharashtra Pollution Control Board under Air and Water Act and a copy shall be submitted to the Environment department before start of any construction work at the site



Maharashtra Pollution Control Board  
5f9fe87fecca0968bddd5a6f

Attached Copy

**MAHARASHTRA POLLUTION CONTROL BOARD**

Phone : (022)-27572730 (022)-27572740 Sub-Regional Office Navi Mumbai-1, Rajgad Bhavan  
7th floor, Sector - 11, C.B.D. Belapur  
Navi Mumbai - 400614

Fax : (022)-27571586  
Email : sronavinumbai1@mpcb.gov.in  
Visit At : <http://mpcb.gov.in>

Date: 02/11/2020

Green/S.S.I

Consent No: SRO-RAIGAD-1/CONSENT/2019/000040

Consent to Operate under Section 28 of the Water (Prevention & Control of Pollution) Act, 1974 & under Section 21 of the Air (Prevention & Control of Pollution) Act, 1981 and Authorization / Renewal of Authorization under Rule 5 of the Hazardous & Other Wastes (Management & Transboundary) Rules 2016

[To be referred as Water Act, Air Act and HW (M&H) Rules respectively].

CONSENT is hereby granted to  
M/s. Larsen & Toubro Limited,  
Plot No.2, Sector 6, Uwe Node, Banandongri,  
Ulwe, Tal - Panvel, Dist - Raigad - 410206,  
located in the area declared under the provisions of the Water Act, Air act and Authorization under the provisions of HW(M&H) Rules and amendments thereto subject to the provisions of the Act and the Rules and the Orders that may be made further and subject to the following terms and conditions:

- The Consent to Operate is granted for a period up to: 31/10/2029.
- The Consent is valid for the manufacture of -

Sr. No.	Activity	Maximum Quantity	LOM
1	Ready Mix Concrete (Captive Plant)	1800	MTM

**3. CONDITIONS UNDER WATER ACT:**

- The daily quantity of trade effluent from the factory shall be 1.0 M3.
- The daily quantity of sewage effluent from the factory shall not exceed 0.8 M3.
- Trade Effluent:** Treatment: The applicant shall provide comprehensive treatment system consisting of primary / secondary and/or tertiary treatment as is warranted with reference to influent quality and operate and maintain the same continuously so as to achieve the quality of the treated effluent to the following standards:

Sr.	Parameter	Standard	Limit
1	pH	Between	5.5 to 9.0
2	Oil & Grease	Not to exceed	10 mg/l
3	Suspended Solids	Not to exceed	100 mg/l
4	BOD 3 days 27 deg C	Not to exceed	100 mg/l
5	COD	Not to exceed	250 mg/l

UAN No: MPCB-CONSENT- 000099150



## GENERAL CONDITIONS

Point 7:- All required sanitary and hygienic measures should be in place before starting construction activities and to be maintained throughout the construction phase

### Attached Photos



## GENERAL CONDITIONS

Point 8:-Adequate drinking water and sanitary facilities should be provided for construction workers at the site. Provision should be made for mobile toilets. The safe disposal of wastewater and solid wastes generated during the construction phase should be ensured

### Attached Photos

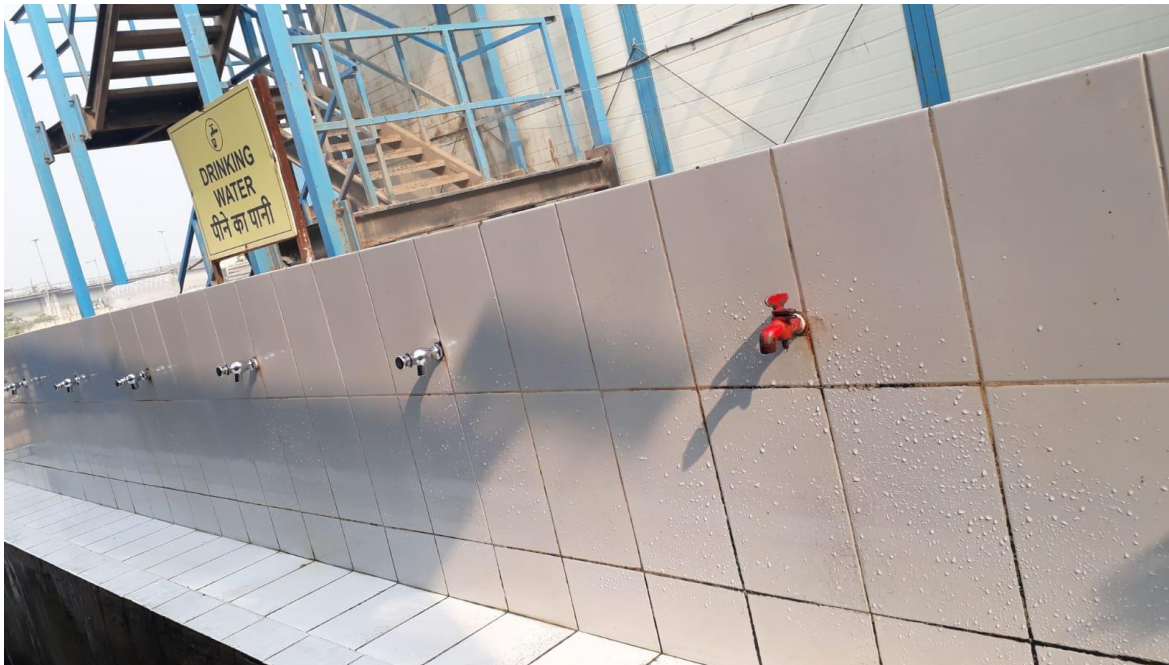

## GENERAL CONDITIONS

Point 9:-The solid waste generated should be properly collected and segregated. DIY/inert solid waste should be disposed of to the approved sites for land filling after recovering recyclable material

### Attached Photos



## GENERAL CONDITIONS

Point 10:- Disposal of muck during construction phase should not create any adverse effect on the neighboring communities and be disposed taking the necessary precautions for general safety and health aspects of people, only in approved sites with the approval of competent authority

All excavated soil has been stocked at site premises only.



## GENERAL CONDITIONS

Point 11:- Arrangement shall be made that wastewater and storm water do not get mixed

Toilets are isolated in location away from project.



## GENERAL CONDITIONS

Point 12:- All the topsoil excavated during construction activities should be stored for use in horticulture/  
Landscape development within the project site

Attached Photos



## GENERAL CONDITIONS

Point 13:- Additional soil for leveling of the proposed site shall be generated within the sites (to the extent possible) so that natural drainage system of the area is protected and improved.

Levelled soil photo attached



## GENERAL CONDITIONS

Point 14:- Green Belt Development shall be carried out considering CPCB guidelines including selection of plant species and in consultation with the local DFO/ Agriculture Dept

Landscape drawing development in progress



## GENERAL CONDITIONS

Point 15:- Soil and ground water samples will be tested to ascertain that there is no threat to ground water quality by leaching of heavy metals and other toxic contaminants expenditure should reported to the MPCB & this department.



**ADITYA ENVIRONMENTAL SERVICES PVT. LTD.**  
Testing Laboratory is certified by ISO 9001:2015 & ISO 45001:2018  
Recognized by MoEFCC as "Environmental Laboratory" valid up to 24.04.2024  
Laboratory: P-1, MIDC Mohopada, P.O. Rasayani, Dist. Raigad Pin 410222  
Tel: 02192 252008, CIN: U74999MH2001PTC132091



### Drinking Water Quality Test Report

Ref. No.: AESPL/LAB/M-21/11/174		Issue Date: 03/12/2021		
Name of Client	:	M/s. L&T Construction, CIDCO Housing Project - Bamandongri I B & F IC- Mumbai		
Name of site	:	CIDCO Housing Project - Bamandongri I B & F IC- Mumbai		
Nature of sample	:	Drinking water		
Location of sample	:	Labour Colony		
Sample identification number	:	M-21/11/174		
Sample Quantity & Container	:	250 ml; G		
Environmental Condition	:	Water clear; Ambient temp. 31°C		
Date of sample drawn	:	29/11/2021		
Date of sample receipt	:	30/11/2021		
Date of sample analysis	:	30/11/2021 - 01/12/2021		
Sample drawn by	:	AESPL		
Sample Transported by	:	AESPL		
Project/ Job Number	:	EK 125WOD1000030 dtd 13Jan 2021		
Reference of sampling	:	AESPL/LAB/QR/7.3.3/R-02		
Method of sampling & preservation	:	AESPL/LAB/SOP/7.3.1/M-01		
Sr. No.	Parameter	Result	Limit As per IS 10500 -2012	Method of analysis
1	Coliforms	Absent /100ml	Absent	IS:15185-2016
2	E-coli	Absent/100ml	Absent	IS:15185-2016

**Conformity Statement:** Water sample is pass as per IS 10500:2012 w.r.t. above mentioned tests.

**Note:**

1. The test report shall not be reproduced except in full, without written approval of laboratory.
2. Results relate only to the items tested.



**Pranali N Patil**  
(Authorized Signatory - Microbiology)

-End of Test Report-

Attached Report

## GENERAL CONDITIONS

Point 16:- Construction spoils, including bituminous material and other hazardous materials must not be allowed to contaminate watercourses and the dumpsites for such material must be secured so that they should not leach into the ground water

Not Applicable

## GENERAL CONDITIONS

Point 17:- Any hazardous waste generated during construction phase should be disposed of as per applicable rules and norms with necessary approvals of the Maharashtra Pollution Control Board

Not Applicable

## GENERAL CONDITIONS

Point 18:- The diesel generator sets to be used during construction phase should be low Sulphur diesel type and should conform to Environments (Protection) Rules prescribed for air and noise emission standards

Not used at site , Power is 100 % on MSEDCL attached Photos



## GENERAL CONDITIONS

Point 19:- The diesel required for operating DG sets shall be stored in underground tanks and if required, clearance from concern authority shall be taken

Not used at site , Power is 100 % on MSEDCL



# Environment Compliance Report

## GENERAL CONDITIONS

Point 20:- Vehicles hired for bringing construction material to the site should be in good condition and should have a pollution check certificate and should conform to applicable air and noise emission standards and should be operated only during non-peak hours.

### Attached Report

Form 59  
[See rules 115 (2)]

**Pollution Under Control Certificate**  
Authorised By :  
Government of Maharashtra

Date : 09/10/2021  
Time : 17:21:25 PM  
Validity upto : 08/04/2022

Certificate SL. No. : MH04300480004862  
Registration No. : MH46AF2723  
Date of Registration : 08/Dec/2014  
Month & Year of Manufacturing : July-2014  
Valid Mobile Number : \*\*\*\*\*7654  
Emission Norms : BHARAT STAGE III  
Fu : DIESEL  
PUJ Code : MH0430048  
GS :  
Fees : Rs.110.0(GST as applicable)  
MIL observation : No

Vehicle Photo with Registration plate  
60 mm x 30 mm

Sr. No.	Pollutant (as applicable)	Units (as applicable)	Emission limits	Measured Value (upto 2 decimal places)
1	Carbon Monoxide (CO)	percentage (%)		
g Emissions	Hydrocarbon, (THC/HC)	ppm		
	CO	percentage (%)		
High idling emissions	RPM	RPM	2500 ± 200	
	Lambda	-	1 ± 0.03	
Smoke Density	Light absorption coefficient	1/metre	2.45	0.81

This PUC certificate is system generated through the national register of motor vehicles and does not require any signature.

Note : 1. Vehicle owners to link their mobile numbers to registered vehicle by logging to <https://vahan.parivahan.gov.in>

Authorised Signature with stamp of PUC operator

## GENERAL CONDITIONS

Point 21:- Ambient noise levels should conform to residential standards both during day and night. Incremental pollution loads on the ambient air and noise quality should be closely monitored during construction phase. Adequate measures should be made to reduce ambient air and noise level during construction phase, so as to conform to the stipulated standards by CPCB/MPCB



**ADITYA ENVIRONMENTAL SERVICES PVT. LTD.**  
Testing Laboratory is certified by ISO 9001:2015&ISO 45001:2018  
Recognized by MoEFCC as "Environmental Laboratory" valid up to 24.04.2024  
Laboratory: P-1, MIDC, Mohopada, P.O. Raseyani, Dist. Raigad Pin 410207  
Tel: 02192 252008, CIN: U74999MH2001PTC132091



TC-7085

## Attached Report

Ambient Air Quality Test Report		Issue Date: 06/12/2021	
Ref. No.:	AESPL/LAB/A- 21/11/100		
Name of Client	M/s. L&T Construction, CIDCO Housing Project - Bamandongri I B & F IC- Mumbai		
Name of Site	CIDCO Housing Project - Bamandongri I B & F IC- Mumbai		
Nature of sample	Ambient Air		
Location of sample	Phase 02, Gate No.1		
Sample Identification number	A- 21/11/100		
Sample Quantity & Container	SO <sub>2</sub> :1 Bottle x 30 ml; NO <sub>2</sub> :1 Bottle x 30 ml; PM <sub>10</sub> -1		
Date of sampling	29/11/2021		
Start Time of sampling	09:15 hrs		
Sampling period	8 hrs		
Date of sample receipt	30/11/2021		
Date of sample analysis	30/11/2021-06/12/2021		
Environmental condition	Climate clear Ambient temp. 32°C		
Monitored & transported by	AESPL		
Sampling equipment	Air Sampler RDS-I-05		
Calibration status	Calibrated on 01/01/2021 Calibration due on 31/12/2021		
Project/Job number	EK125WOD1000030 dtd 13Jan 2021		
Reference of sampling	AESPL/LAB/OR/7.3.3/R-02		
Method of sampling & preservation	AESPL/LAB/SOP/7.3.1/A-01		
Sr.No.	Parameter	Result	Limits # Unit Method of Analysis
1.	SO <sub>2</sub>	12.7	80 * µg/m <sup>3</sup> IS 5182 (Part 2) RA2017
2.	NO <sub>2</sub>	23.9	80 * µg/m <sup>3</sup> IS 5182 (Part 6) RA2017
3.	PM <sub>10</sub>	64.7	100 * µg/m <sup>3</sup> IS 5182 (Part 23) RA2017
4.	CO	0.37	04 ** mg/m <sup>3</sup> IS 5182 (part 10) RA2019

[\*] Specified under National Ambient Air Quality Standards by CPCB.

[\*\*] 24 hourly monitoring values; [\*\*\*] 1 hourly monitoring values; [\*\*\*\*] annually monitoring values.

**Conformity Statement:** The monitoring undertaken indicates that Ambient Air Quality Values for monitored parameters are within the levels stipulated under National Ambient Air Quality Standards (NAAQS)2009.

### Note:

- The test report shall not be reproduced except in full, without written approval of laboratory.
- Results relate only to the items tested.
- Any query related to this report will be entertained within 15 days of the report issue date only.
- Decision Rule is applied.



Chetan A Kadam  
(Authorized Signatory - Pollution & Environment)  
-End of Test Report-



**ADITYA ENVIRONMENTAL SERVICES PVT. LTD.**  
Testing Laboratory is certified by ISO 9001:2015&ISO 45001:2018  
Recognized by MoEFCC as "Environmental Laboratory" valid up to 24.04.2024  
Laboratory: P-1, MIDC, Mohopada, P.O. Raseyani, Dist. Raigad Pin 410222  
Tel: 02192 252008, CIN: U74999MH2001PTC132091



TC-7085

## DG Noise Quality Test Report

Ref: AESPL/LAB/N-21/11/75		Report Date: 02/12/2021				
Name of the client	M/s. L&T Construction, CIDCO Housing Project - Bamandongri I B & F IC- Mumbai					
Name of site	CIDCO Housing Project - Bamandongri I B & F IC- Mumbai					
Monitoring date	29/11/2021					
Environmental condition	Climate clear; Ambient Temp. 29°C					
Monitored & transported by	AESPL					
Project/Job Number	EK125WOD1000030 dtd 13Jan 2021					
Reference of sampling	AESPL/LAB/OR/7.3.3/R-02					
Method of sampling	IS 4758 RA:2002					
Instrument used	Noise meter - Centre C-390 SL-1-14					
Calibration status	Calibration details: 03/11/2021 to 02/11/2022					
		Sound Pressure Level dB(A)				
Sr. No.	Location	Readings from 0.5 m away from DG				
		East	West	South	North	Avg. Difference
1.	Door closed	74.6	74.9	73.0	73.8	74.1
	Door opened	98.3	98.9	99.8	99.6	99.2

### Limits:

- EP Act Standard 75 dBA at 0.5m from DG set
- Insertion loss of 25dBA as per consent

**Conformity Statement:** The monitoring undertaken indicates that DG Noise Quality values are within limits.

### Note:

- The test report shall not be reproduced except in full, without written approval of laboratory
- Results relate only to the items tested
- DG set Sound Pressure Level measured at 0.5m from the enclosure



Chetan A Kadam  
(Authorized Signatory - Pollution & Environment)  
-End of Test Report-

## GENERAL CONDITIONS

Point 22:- Fly ash should be used as building material in the construction as per the provisions of Fly Ash Notification of September 1999 and amended as on 27th August 2003. (The above condition is applicable only if the project site is located within the 100Km of Thermal Power Stations). XX111. Ready mixed concrete must be used in building construction.

Not Applicable



## GENERAL CONDITIONS

Point 23:- Ready mixed concrete must be used in building construction.

Attached Photos



## GENERAL CONDITIONS

Point 24:- Storm water control and its re-use as per CGWB and BIS standards for various applications

Not Applicable

## GENERAL CONDITIONS

Point 25:- Water demand during construction should be reduced by use of pre-mixed concrete, curing agents and other best practices referred.

Using Coaltar as curing compound as well as Waterproofing agent. Attached Photos



## GENERAL CONDITIONS

Point 26:-The ground water level and its quality should be monitored regularly in consultation with Ground Water Authority

No Water is drawn from ground

## GENERAL CONDITIONS

Point 27:- The installation of the Sewage Treatment Plant (STP) should be certified by an independent expert and a report in this regard should be submitted to the MPCB and Environment department before the project is commissioned for operation. Discharge of this unused treated effluent if any should be discharge in the sewer line. Treated effluent emanating from STP shall be recycled/ refused to the maximum extent possible. Discharge of this unused treated effluent if any should be discharge in the sewer line. Treatment of 100% grey water by decentralized treatment should be done. Necessary measures should be made to mitigate the odour problem from STP

### Attached Photos



**ADITYA ENVIRONMENTAL SERVICES PVT. LTD.**  
Testing Laboratory is certified by ISO 9001:2015 & ISO 45001:2018  
Recognized by Maharashtra Environmental Laboratory \* valid upto: 24.04.2024  
Laboratory - P-1, MIDC, Mohopada, P.O. Raayani, Dist. Raigad Pin 410222  
Tel: 02152-232608, CN: 17/49908E200/ITC/12/201



TC-2085

#### Drinking Water Quality Test Report

Ref. No.:	AESPL/LAB/M-21/11/174	Issue Date:	03/12/2021	
Name of Client	M/A. L&T Construction, CIDCO Housing Project - Bamandongri I B & F I.C. Mumbai			
Name of site	CIDCO Housing Project - Bamandongri I B & F Mumbai			
Nature of sample	Drinking water			
Location of sample	Labour Colony			
Sample identification number	M-21/11/174			
Sample Quantity & Container	250 ml, G			
Environmental Condition	Water clear; Ambient temp. 31°C			
Date of sample drawn	29/11/2021			
Date of sample receipt	30/11/2021			
Date of sample analysis	30/11/2021 - 01/12/2021			
Sample drawn by	AESPL			
Sample Transported by	AESPL			
Project/ Job Number	EK15W0010000300 And 13Jan 2021			
Reference of sampling	AESPL/LAB/Q08/7.3.3/R-02			
Method of sampling & preservation	AESPL/LAB/SOP/7.3.1/M-01			
Sr. No.	Parameter	Result	Limit As per IS 10500:2012	Method of analysis
1	Coliforms	Absent /100ml	Absent	IS:15185-2016
2	E-coli	Absent/100ml	Absent	IS:15185-2016

**Conformity Statement:** Water sample is pass as per IS 10500:2012 w.r.t. above mentioned tests.

#### Note:

- The test report shall not be reproduced except in full, without written approval of laboratory.
- Results relate only to the items tested.



**Pranali N Patil**  
(Authorized Signatory - Microbiology)

-End of Test Report-

## GENERAL CONDITIONS

Point 28:- Permissions to draw ground water and construction of basement if any shall be obtained from the competent Authority prior to construction/operation of the project

No Water is drawn from ground

## GENERAL CONDITIONS

Point 29:- Separation of grey and black water should be done by the use of dual plumbing line for separation of grey and black water

Attached Drawing

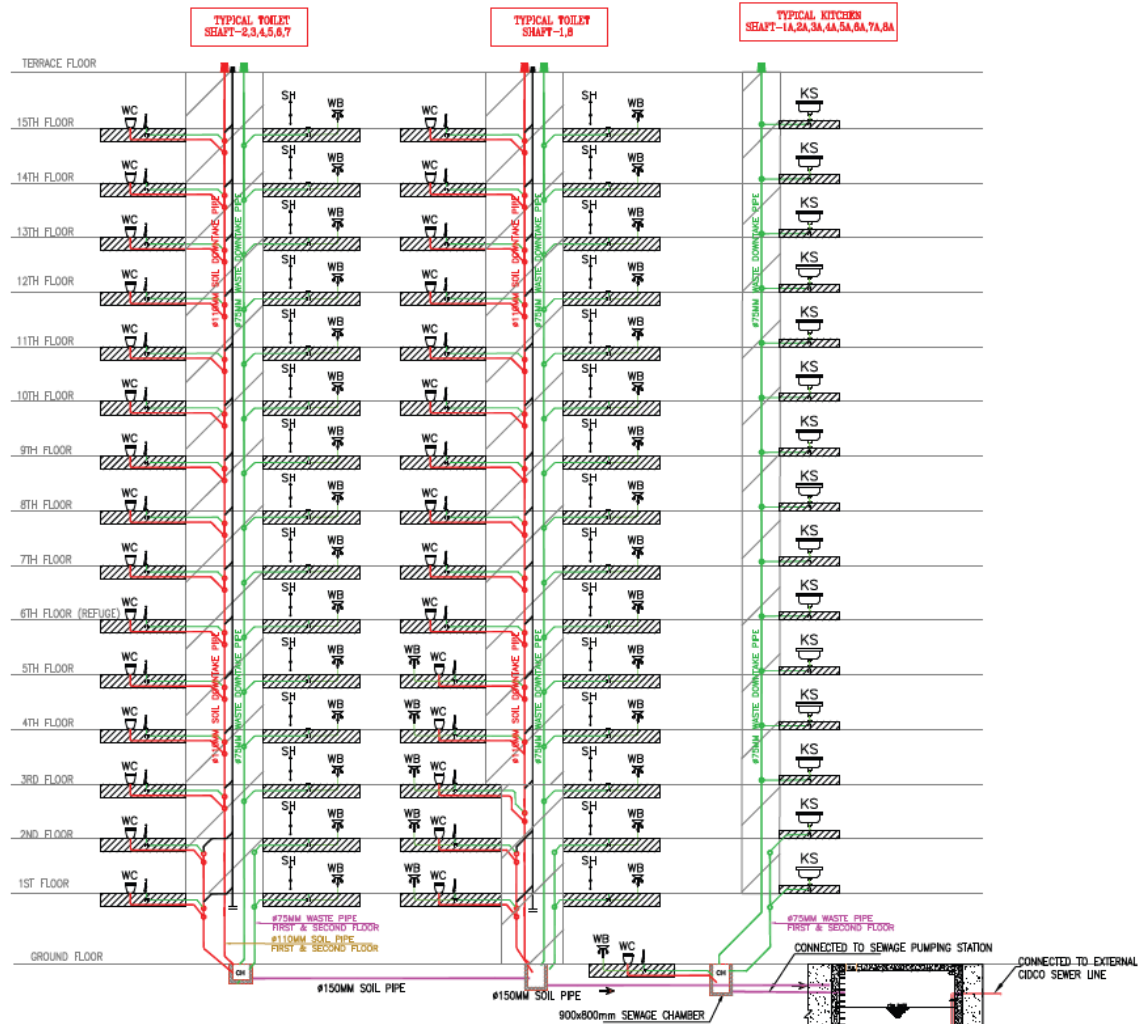

## GENERAL CONDITIONS

Point 30:- Fixtures for showers, toilet flushing, and drinking should be of low flow either by use of aerators or pressure reducing devices or sensor-based control.

Material Selection in process



## GENERAL CONDITIONS

Point 31:- Use of glass may be reduced up to 40% to reduce the electricity consumption and load on air conditioning. If necessary, use high quality double glass with special reflective coating in windows.

Will be implemented in the proposed Commercial building once façade is finalized.  
For Residential buildings not applicable.

## GENERAL CONDITIONS

Point 32:- Roof should meet prescriptive requirement as per Energy Conservation Building Code by using appropriate thermal insulation material to fulfil requirement.

Attached drawings.

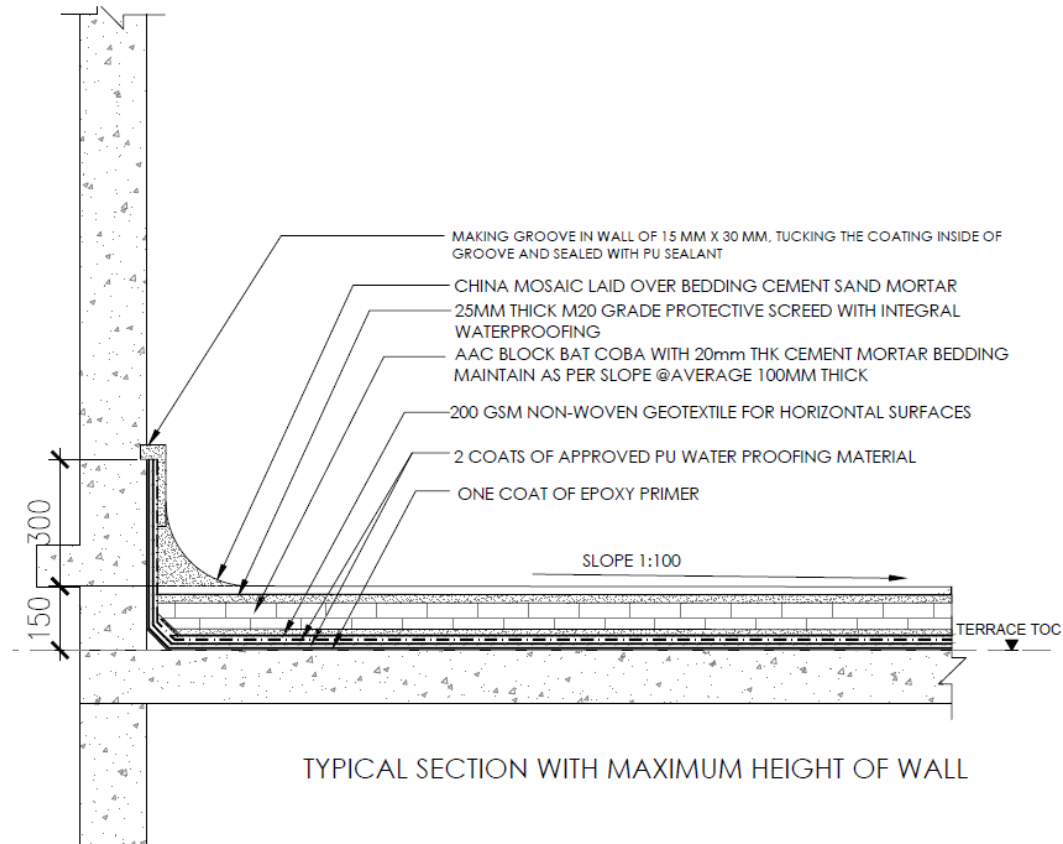

## GENERAL CONDITIONS

Point 33:- Energy conservation measures like installation of CFLs /TFLs for the lighting the areas outside the building should be integral part of the project design and should be in place before project commissioning. Use CFLs and TFLs should be properly collected and disposed of /sent for recycling as per the prevailing guidelines/rules of the regulatory authority to avoid mercury contamination. Use of solar panels may be done to the extent possible like installing solar streetlights, common solar water heaters system. Project proponent should install, after checking feasibility, solar plus hybrid non-conventional energy source as source of energy.

Attached Photos of LED lights



## GENERAL CONDITIONS

Point 34:- Diesel power generating sets proposed as source of backup power for elevators and common area illumination during operation phase should be of enclosed type and conform to rules made under the Environment (Protection) Act, 1986. The height of stack of DG sets should be equal to the height needed for the combined capacity of all proposed DG sets. Use low Sulphur diesel. The location of the DG sets may be decided with in consultation with Maharashtra Pollution Control Board.

Material Selection in process

## GENERAL CONDITIONS

Point 35:- Noise should be controlled to ensure that it does not exceed the prescribed standards. During night-time the noise levels measured at the boundary of the building shall be restricted to the permissible levels to comply with the prevalent regulations.

## Attached Report



**ADITYA ENVIRONMENTAL SERVICES PVT. LTD.**  
Testing Laboratory is certified by ISO 9001:2015&ISO 45001:2018  
Recognized by MoEFCC as "Environmental Laboratory" valid up to 24.04.2024  
Laboratory: P-1, MIDC, Mohopada, P.O. Ranajuni, Dist: Raigad Pin-410222  
Tel: 02192 252008, CIN: U74999MH2001PTC132091



TC-7085

### DG Noise Quality Test Report

Ref: AESPL/LAB/N-21/11/75 **Report Date:** 02/12/2021

<b>Name of the client</b>	: M/s. L&T Construction, CIDCO Housing Project - Bamandongri IB & F IC- Mumbai						
<b>Name of site</b>	: CIDCO Housing Project - Bamandongri IB & F IC- Mumbai						
<b>Monitoring date</b>	: 29/11/2021						
<b>Environmental condition</b>	: Climate clear; Ambient Temp. 29°C						
<b>Monitored &amp; transported by</b>	: AESPL						
<b>Project/ Job Number</b>	: EK125WOD1000030 dtd 13jan 2021						
<b>Reference of sampling</b>	: AESPL/LAB/QR/7.3.3/R-02						
<b>Method of sampling</b>	: IS 4758 RA:2002						
<b>Instrument used</b>	: Noise meter - Centre C-390 SL-I-14						
<b>Calibration status</b>	: Calibration details: 03/11/2021 to 02/11/2022						
<b>Sound Pressure Level dB(A)</b>							
Sr. No.	Location	Readings from 0.5 m away from DG				Avg.	Difference
		East	West	South	North		
1.	Door closed	74.6	74.9	73.0	73.8	74.1	25.1
	Door opened	98.3	98.9	99.8	99.6	99.2	

#### Limits:

- EP Act Standard 75 dBA at 0.5m from DG set
- Insertion loss of 25dBA as per consent

**Conformity Statement:** The monitoring undertaken indicates that DG Noise Quality values are within limits.

#### Note:

- The test report shall not be reproduced except in full, without written approval of laboratory
- Results relate only to the items tested
- DG set Sound Pressure Level measured at 0.5m from the enclosure



**Chetan A Kadam**  
(Authorized Signatory - Pollution & Environment)  
-End of Test Report-

## GENERAL CONDITIONS

Point 36:- Traffic congestion near the entry and exit points from the roads adjoining the proposed project site must be avoided. Parking should be fully internalized, and no public space should be utilized.

Planned accordingly.



## GENERAL CONDITIONS

Point 38:- The building should have adequate distance between them to allow movement of fresh air and passage of natural light, air and ventilation

Day light , Wind analysis report uploaded by MOEF Consultant on Portal

## GENERAL CONDITIONS

Point 39:- Regular supervision of the above and other measures for monitoring should be in place all through the construction phase, to avoid disturbance to the surroundings.

### Attached report



**ADITYA ENVIRONMENTAL SERVICES PVT. LTD.**  
Testing Laboratory is certified by ISO 9001:2015&ISO 45001:2018  
Recognized by MoEFCC as "Environmental Laboratory" valid up to 24.04.2024  
Laboratory: P-1, MIDC, Mohopada, P.O. Rasayani, Dist. Raigad Pin 410227  
Tel: 02192 252008, CIN: U74999MH2001PTC132091



TC-7085



**ADITYA ENVIRONMENTAL SERVICES PVT. LTD.**  
Testing Laboratory is certified by ISO 9001:2015&ISO 45001:2018  
Recognized by MoEFCC as "Environmental Laboratory" valid up to 24.04.2024  
Laboratory: P-1, MIDC, Mohopada, P.O. Rasayani, Dist. Raigad Pin 410227  
Tel: 02192 252008, CIN: U74999MH2001PTC132091



TC-7085

#### Ambient Air Quality Test Report

Ref. No.: AESPL/LAB/A- 21/11/100 Issue Date: 06/12/2021

<b>Name of Client</b>	: M/s. L&T Construction, CIDCO Housing Project - Bamandongri I B & F IC- Mumbai		
<b>Name of Site</b>	: CIDCO Housing Project - Bamandongri I B & F IC- Mumbai		
<b>Nature of sample</b>	: Ambient Air		
<b>Location of sample</b>	: Phase 02, Gate No.1		
<b>Sample Identification number</b>	: A- 21/11/100		
<b>Sample Quantity &amp; Container</b>	: SO <sub>2</sub> :1 Bottle x 30 ml; NO <sub>2</sub> :1 Bottle x 30 ml; PM <sub>10</sub> -1		
<b>Date of sampling</b>	: 29/11/2021		
<b>Start Time of sampling</b>	: 09:15 hrs		
<b>Sampling period</b>	: 8 hrs		
<b>Date of sample receipt</b>	: 30/11/2021		
<b>Date of sample analysis</b>	: 30/11/2021-06/12/2021		
<b>Environmental condition</b>	: Climate clear Ambient temp. 32°C		
<b>Monitored &amp; transported by</b>	: AESPL		
<b>Sampling equipment</b>	: Air Sampler RDS-I-05		
<b>Calibration status</b>	: Calibrated on 01/01/2021 Calibration due on 31/12/2021		
<b>Project/ Job number</b>	: EK125WOD1000030 dtd 13Jan 2021		
<b>Reference of sampling</b>	: AESPL/LAB/QR/7.3.3/R-02		
<b>Method of sampling &amp; preservation</b>	: AESPL/LAB/SOP/7.3.1/A-01		
<b>Sr.No.</b>	<b>Parameter</b>	<b>Result</b>	<b>Limits # Unit Method of Analysis</b>
1.	SO <sub>2</sub>	12.7	80 * µg/m <sup>3</sup> IS 5182 (Part 2) RA2017
2.	NO <sub>2</sub>	23.9	80 * µg/m <sup>3</sup> IS 5182 (Part 6) RA2017
3.	PM <sub>10</sub>	64.7	100 * µg/m <sup>3</sup> IS 5182 (Part 23) RA2017
4.	CO	0.37	04 ** mg/m <sup>3</sup> IS 5182 (part 10) RA2019

[#] Specified under National Ambient Air Quality Standards by CPCB.

[\*] 24 hourly monitoring values; [\*\*] 1 hourly monitoring values; [\*\*\*] annually monitoring values.

**Conformity Statement:** The monitoring undertaken indicates that Ambient Air Quality values for monitored parameters are within the levels stipulated under National Ambient Air Quality Standards (NAAQS)2009.

#### Note:

- The test report shall not be reproduced except in full, without written approval of laboratory.
- Results relate only to the items tested.
- Any query related to this report will be entertained within 15 days of the report issue date only.
- Decision Rule is applied.



Chetan A Kadam  
(Authorized Signatory - Pollution & Environment)  
-End of Test Report-

#### DG Noise Quality Test Report

Ref: AESPL/LAB/N-21/11/75 Report Date: 02/12/2021

<b>Name of the client</b>	: M/s. L&T Construction, CIDCO Housing Project - Bamandongri I B & F IC- Mumbai						
<b>Name of site</b>	: CIDCO Housing Project - Bamandongri I B & F IC- Mumbai						
<b>Monitoring date</b>	: 29/11/2021						
<b>Environmental condition</b>	: Climate clear; Ambient Temp. 29°C						
<b>Monitored &amp; transported by</b>	: AESPL						
<b>Project/ Job Number</b>	: EK125WOD1000030 dtd 13Jan 2021						
<b>Reference of sampling</b>	: AESPL/LAB/QR/7.3.3/R-02						
<b>Method of sampling</b>	: IS 4758 RA:2002						
<b>Instrument used</b>	: Noise meter - Centre C-390 SL-I-14						
<b>Calibration status</b>	: Calibration details: 03/11/2021 to 02/11/2022						
<b>Sound Pressure Level dB(A)</b>							
<b>Sr. No.</b>	<b>Location</b>	<b>Readings from 0.5 m away from DG</b>				<b>Avg.</b>	<b>Difference</b>
		<b>East</b>	<b>West</b>	<b>South</b>	<b>North</b>		
1.	Door closed	74.6	74.9	73.0	73.8	74.1	25.1
	Door opened	98.3	98.9	99.8	99.6	99.2	

#### Limits:

- EP Act Standard 75 dBA at 0.5m from DG set
- Insertion loss of 25dBA as per consent

**Conformity Statement:** The monitoring undertaken indicates that DG Noise Quality values are within limits.

#### Note:

- The test report shall not be reproduced except in full, without written approval of laboratory
- Results relate only to the items tested
- DG set Sound Pressure Level measured at 0.5m from the enclosure



Chetan A Kadam  
(Authorized Signatory - Pollution & Environment)  
-End of Test Report-



## GENERAL CONDITIONS

Point 40:- Under the provisions of Environment (Protection) Act, 1986. legal action shall be initiated against the project proponent if it was found that construction of the project has been started without obtaining environmental clearance

Noted

## GENERAL CONDITIONS

Point 41:- Six monthly monitoring reports should be submitted to the Regional office MOEF, Bhopal with copy to this department and MPCB.



स्वातंत्र्याचा अमृत महोत्सव



### CITY AND INDUSTRIAL DEVELOPMENT CORPORATION OF MAHARASHTRA LIMITED

(CIN - U99999 MH 1970 SGC - 014574)

**REGD. OFFICE:**

"NIRMAL", 2nd Floor, Nariman Point,  
Mumbai - 400 021.  
PHONE : 00-91-22-6650 0900  
FAX : 00-91-22-2202 2509

**HEAD OFFICE:**

CIDCO Bhavan, CBD Belapur,  
Navi Mumbai - 400 614.  
PHONE: 00-91-22-6791 8100  
FAX : 00-91-22-6791 8166

**Ref. No.**

**Date :**

To,

The Member Secretary,  
State Level Environmental Impact Assessment Authority (SEIAA)  
Environment Department  
Room No. 217, 2nd Floor,  
Mantralaya, Mumbai -400 032

**Sub:** Submission of Six-Monthly compliance status report up to 30<sup>th</sup> Nov 2021

**Ref:** -Grant of Environmental Clearance from SEIAA, vide letter no. SIA/MH/MIS/50802/2019 dated 31.03.2020 for Pradhan Mantri Awas Yojana (PMAY) Housing scheme at Plot no. 2, Sector- 6, near Bamandongri Railway Station, Ulwe node, Navi Mumbai, Taluka Panvel, District-Raigad.

Respected Sir/ Madam,

We are hereby enclosing six monthly compliance status report for the month of 30<sup>th</sup> Nov 2021 as per General Condition in the issued Environmental Clearance.

This is for your kind information and records.

Thanking You,

Yours faithfully,

(R.B. DHAYATKAR)  
CHIEF ENGINEER (NMIA)  
CIDCO LTD.,  
3rd Floor, CIDCO Bhavan,  
CBD Belapur, Navi Mumbai-400614

## GENERAL CONDITIONS

Point 42:- Project proponent shall ensure completion of STP, MSW disposal facility, green belt development prior to occupation of the buildings. As agreed during the SEIAA meeting, PP to explore possibility of utilizing excess treated water in the adjacent area for gardening before discharging it into sewer line No physical occupation or allotment will be given unless all above said environmental infrastructure is installed and made functional including water requirement in Para 2. Prior certification from appropriate authority shall be obtained.

Noted

## GENERAL CONDITIONS

Point 43:- Wet garbage should be treated by Organic Waste Converter and treated waste (manure) should be utilized in the existing premises for gardening. And no wet garbage will be disposed outside the premises. Local authority should ensure this.

OWC Technology report attached



## MNC Process

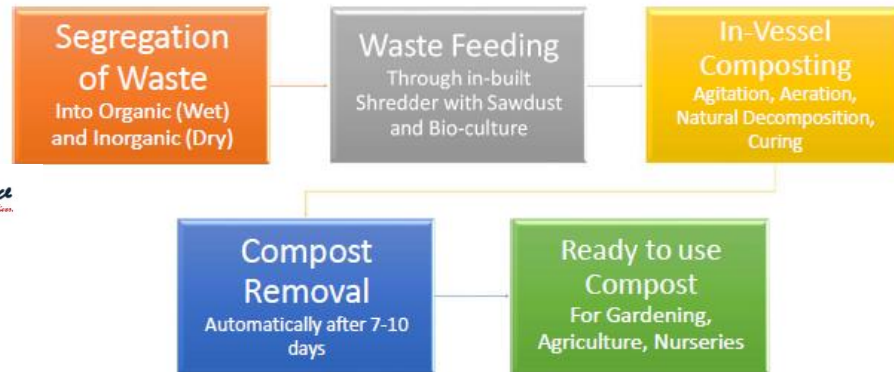

MNC  
Advanced In-Vessel Natural Composter

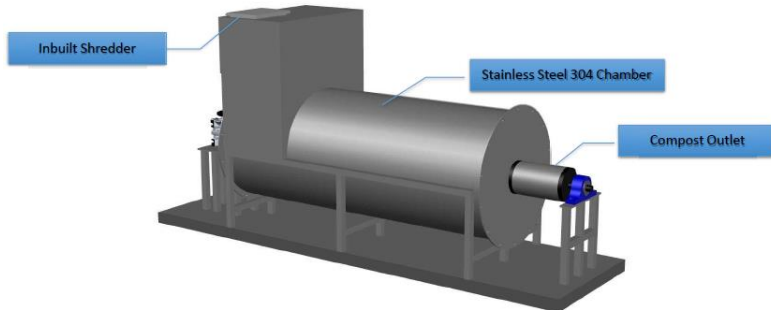

## GENERAL CONDITIONS

Point 44:- Local body should ensure that no occupation certification is issued prior to operation of STP/MSW site etc. with due permission of MPCB

Noted

## GENERAL CONDITIONS

Point 45:-A complete set of all the documents submitted to Department should be forwarded to the Local authority and MPCB

 स्वातंत्र्याचा अमृत महोत्सव	 <b>CIDCO</b> WE MAKE CITIES
<b>CITY AND INDUSTRIAL DEVELOPMENT CORPORATION OF MAHARASHTRA LIMITED</b> (CIN - U99999 MH 1970 SGC - 014574)	
<b>REGD. OFFICE:</b> "NIRMAL", 2nd Floor, Nariman Point, Mumbai - 400 021. PHONE : 00-91-22-6650 0900 FAX : : 00-91-22-2202 2509	<b>HEAD OFFICE:</b> CIDCO Bhavan, CBD Belapur, Navi Mumbai - 400 614. PHONE: 00-91-22-6791 8100 FAX : : 00-91-22-6791 8166
<b>Ref. No.</b>	<b>Date :</b>
To,	
The Member Secretary, State Level Environmental Impact Assessment Authority (SEIAA) Environment Department Room No. 217, 2nd Floor, Mantralaya, Mumbai -400 032	
<b>Sub:</b> Submission of Six-Monthly compliance status report up to 30 <sup>th</sup> Nov 2021	
<b>Ref:</b> -Grant of Environmental Clearance from SEIAA, vide letter no. SIA/MH/MIS/50802/2019 dated 31.03.2020 for Pradhan Mantri Awas Yojana (PMAY) Housing scheme at Plot no. 2, Sector- 6, near Bamandongri Railway Station, Ulwe node, Navi Mumbai, Taluka Panvel, District-Raigad.	
Respected Sir/ Madam,	
We are hereby enclosing six monthly compliance status report for the month of 30 <sup>th</sup> Nov 2021 as per General Condition in the issued Environmental Clearance.	
This is for your kind information and records.	
Thanking You,	
Yours faithfully, 	
(R.B. DHAYATKAR) CHIEF ENGINEER (NMIA) CIDCO LTD., 3rd Floor, CIDCO Bhavan, CBD Belapur, Navi Mumbai-400614	

## GENERAL CONDITIONS

Point 46:- In the case of any change(s) in the scope of the project, the project would require a fresh appraisal by this Department.

Not Applicable

## GENERAL CONDITIONS

Point 47:- A separate environment management cell with qualified staff shall be set up for implementation of the stipulated environmental safeguards.

Noted



## GENERAL CONDITIONS

Point 48:- A separate environment management cell with qualified staff shall be set up for implementation of the stipulated environmental safeguards.

Noted

## GENERAL CONDITIONS

Point 49:- The project management shall advertise at least in two local newspapers widely circulated in the region around the project, one of which shall be in the Marathi language of the local concerned within seven days of issue of this letter, informing that the project has been accorded environmental clearance and copies of clearance letter are available with the Maharashtra Pollution Control Board and may also be seen at Website at <http://parivesh.nic.in>

MUMBAI  
TUESDAY  
MAY 24, 2022

**Hindustan Times**



**PUBLIC NOTICE**

**CIDCO PMAY Housing  
ENVIRONMENTAL CLEARANCE**

The State Environmental Impact Assessment Authority (SEIAA), Maharashtra has accorded Environmental Clearance (EC) for CIDCO's Residential cum Commercial housing complex under PMAY Scheme, Package-IV (out of Package-I to IV vide (i) No. SIA/MH/MIS/50802/2019 dated 31/03/2020 for proposed Pradhan Mantri Awas Yojana (PMAY) housing scheme at Plot No. 2, Sector-6 near Bamandongri Railway Station, Ulwe Node, Navi Mumbai, Taluka-Panvel, District-Raigad. (ii) No. SIA/MH/MIS/53158/2019 dated 27/10/2020 for proposed Pradhan Mantri Awas Yojana (PMAY) housing scheme at Plot No. 03, Sector 16A near Kharkopar Railway Station (East), Ulwe Node, Navi Mumbai, Taluka-Panvel, District-Raigad & (iii) No. SIA/MH/MIS/53197/2020 dated 27/10/2020 for proposed Pradhan Mantri Awas Yojana (PMAY) housing scheme at Plot No. 01, Sector 39 at Taloja, Navi Mumbai.

The copies of environmental Clearance are available for reference with Maharashtra State Pollution Control Board and may also be seen at Website at <http://parivesh.nic.in>

The State Environmental Impact Assessment Authority (SEIAA) has accorded the environmental clearance for the said project under the provisions of EIA Notification, 2006.

CIN - U99999 MH 1970 SGC-014574  
[www.cidco.maharashtra.gov.in](http://www.cidco.maharashtra.gov.in)

**Chief Engineer (NMIA)**  
CIDCO/PR/085/2022-23

मंगळवार,  
दि. २४ मे २०२२

**सामना**



**सार्वजनिक सूचना**

**सिडको प्रधानमंत्री आवास योजना  
पर्यावरण मंजूरी**

राज्य पर्यावरण प्रभाव मूल्यांकन प्राधिकरण (SEIAA), महाराष्ट्र यांनी प्रधानमंत्री आवास योजनेतर्गत सिडकोच्या निवासी तथा व्यावसायिक गृहनिर्माण प्रकल्पांतर्गत पॅकेज-४ ला (पॅकेज १ ते ४ पैकी) पर्यावरण मंजूरी (१) No. SIA/MH/MIS/५०८०२/२०१९ दिनांक ३१.०३.२०२० अन्वये, प्लॉट नं. २, सेक्टर ६, बामणडोंगरी रेल्वे स्थानकाजवळ, उलवे नोड, नवी मुंबई, तालुका-पनवेल, जिल्हा-रायगड यांना (२) No. SIA/MH/MIS/५३१५८/२०१९ दिनांक २७.१०.२०२० अन्वये, प्लॉट क्र. ३, सेक्टर १६A खारकोपर रेल्वे स्थानक (पूर्व), उलवे नोड, नवी मुंबई, तालुका-पनवेल, जिल्हा-रायगड यांना व (३) No. SIA/MH/MIS/५३१९७/२०२० दिनांक २७.१०.२०२० अन्वये, प्लॉट क्र. १, सेक्टर ३९, तळोजा, नवी मुंबई यांना पर्यावरणाच्या दृष्टीकोनातून मंजूरी दिली आहे.

सदर मंजूरीच्या प्रती महाराष्ट्र प्रदूषण नियंत्रण महामंडळ यांच्याकडे उपलब्ध आहेत व त्या <http://parivesh.nic.in> या वेबसाईट वर देखील पाहता येईल.

राज्य पर्यावरण प्रभाव मूल्यमापन प्राधिकरण (SEIAA) ने EIA अधिसूचना, २००६ च्या तरतुदीनुसार उक्त प्रकल्पासाठी पर्यावरण मंजूरीला मान्यता दिली आहे.

CIN - U99999 MH 1970 SGC-014574  
[www.cidco.maharashtra.gov.in](http://www.cidco.maharashtra.gov.in)

**मुख्य अभियंता (न.मुं.आं.वि.)**  
सिडको/जनसंपर्क/०८५/२०२२-२३

## GENERAL CONDITIONS

Point 50:- Project management should submit half yearly compliance reports in respect of the stipulated prior environment clearance terms and conditions in hard & soft copies to the MPCB & this department, on 1st June & 1st December of each calendar year.



### CITY AND INDUSTRIAL DEVELOPMENT CORPORATION OF MAHARASHTRA LIMITED

(CIN - U99999 MH 1970 SGC - 014574)

**REGD. OFFICE:**

"NIRMAL", 2nd Floor, Nariman Point,  
Mumbai - 400 021.  
PHONE : 00-91-22-6650 0900  
FAX : : 00-91-22-2202 2509



**HEAD OFFICE:**

CIDCO Bhavan, CBD Belapur,  
Navi Mumbai - 400 614.  
PHONE: 00-91-22-6791 8100  
FAX : 00-91-22-6791 8166

**Ref. No.**

**Date :**

To,

The Member Secretary,  
State Level Environmental Impact Assessment Authority (SEIAA)  
Environment Department  
Room No. 217, 2nd Floor,  
Mantralaya, Mumbai -400 032

**Sub:** Submission of Six-Monthly compliance status report up to 30<sup>th</sup> Nov 2021

**Ref:** -Grant of Environmental Clearance from SEIAA, vide letter no. SIA/MH/MIS/50802/2019 dated 31.03.2020 for Pradhan Mantri Awas Yojana (PMAY) Housing scheme at Plot no. 2, Sector- 6, near Bamandongri Railway Station, Ulwe node, Navi Mumbai, Taluka Panvel, District-Raigad.

Respected Sir/ Madam,

We are hereby enclosing six monthly compliance status report for the month of 30<sup>th</sup> Nov 2021 as per General Condition in the issued Environmental Clearance.

This is for your kind information and records.

Thanking You,

Yours faithfully,



(R.B. DHAYATKAR)  
CHIEF ENGINEER (NMIA)  
CIDCO LTD.,  
3rd Floor, CIDCO Bhavan,  
CBD Belapur, Navi Mumbai-400614

## GENERAL CONDITIONS

Point 51:- A copy of the clearance letter shall be sent by proponent to the concerned Municipal Corporation and the local NGO, if any, from whom suggestions/representations, if any, were received while processing the proposal. The clearance letter shall also be put on the website of the Company by the proponent.

Not Applicable

## GENERAL CONDITIONS

Point 52:- The proponent shall upload the status of compliance of the stipulated EC conditions, including results of monitored data on their website and shall update the same periodically. It shall simultaneously be sent to the Regional Office of MOEF, the respective Zonal Office of CPCB and the SPCB. The criteria pollutant levels namely, SPM, RSPM, SO<sub>2</sub>, NO<sub>x</sub> (ambient levels as well as stack emissions) or critical sector parameters, indicated for the project shall be monitored and displayed at a convenient location near the main gate of the company in the public domain.



महाराष्ट्र सरकार  
असुत महोत्सव

**CITY AND INDUSTRIAL DEVELOPMENT CORPORATION OF MAHARASHTRA LIMITED**  
(CIN - U99999 MH 1970 SGC - 014574)

**REGD. OFFICE:**  
"NIRMAL", 2nd Floor, Nariman Point,  
Mumbai - 400 021.  
PHONE : 00-91-22-6650 0900  
FAX : 00-91-22-2202 2509



**HEAD OFFICE:**  
CIDCO Bhavan, CBD Belapur,  
Navi Mumbai - 400 614.  
PHONE: 00-91-22-6791 8100  
FAX : 00-91-22-6791 8166

**Ref. No.**

**Date :**

To,

The Member Secretary,  
State Level Environmental Impact Assessment Authority (SEIAA)  
Environment Department  
Room No. 217, 2nd Floor,  
Mantralaya, Mumbai -400 032

**Sub:** Submission of Six-Monthly compliance status report up to 30<sup>th</sup> Nov 2021

**Ref:** -Grant of Environmental Clearance from SEIAA, vide letter no. SIAMH/MIS/50802/2019 dated 31.03.2020 for Pradhan Mantri Awas Yojana (PMAY) Housing scheme at Plot no. 2, Sector- 6, near Baramandongri Railway Station, Ulwe node, Navi Mumbai, Taluka Panvel, District-Raigad.

Respected Sir/ Madam,

We are hereby enclosing six monthly compliance status report for the month of 30<sup>th</sup> Nov 2021 as per General Condition in the issued Environmental Clearance.

This is for your kind information and records.

Thanking You,

Yours faithfully,



(R.B. DHAYATKAR)  
CHIEF ENGINEER (NMIA)  
CIDCO LTD.,  
3rd Floor, CIDCO Bhavan,  
CBD Belapur, Navi Mumbai-400614

## GENERAL CONDITIONS

Point 53:- The project proponent shall also submit six monthly reports on the status of compliance of the stipulated EC conditions including results of monitored data (both in hard copies as well as by e-mail) to the respective Regional Office of MOEF, the respective Zonal Office of CPCB and the SPCB.



**Ref. No.**

**Date :**

To,  
The Member Secretary,  
State Level Environmental Impact Assessment Authority (SEIAA)  
Environment Department  
Room No. 217, 2nd Floor,  
Mantralaya, Mumbai -400 032

**Sub:** Submission of Six-Monthly compliance status report up to 30<sup>th</sup> Nov 2021

**Ref:** -Grant of Environmental Clearance from SEIAA, vide letter no. SIA/MH/MIS/50802/2019 dated 31.03.2020 for Pradhan Mantri Awas Yojana (PMAY) Housing scheme at Plot no. 2, Sector- 6, near Bamandongri Railway Station, Ulwe node, Navi Mumbai, Taluka Panvel, District-Raigad.

Respected Sir/ Madam,

We are hereby enclosing six monthly compliance status report for the month of 30<sup>th</sup> Nov 2021 as per General Condition in the issued Environmental Clearance.

This is for your kind information and records.

Thanking You,

Yours faithfully,



(R.B. DHAYATKAR)  
CHIEF ENGINEER (NMIA)  
CIDCO LTD.,  
3rd Floor, CIDCO Bhavan,  
CBD Belapur, Navi Mumbai-400614

## GENERAL CONDITIONS

Point 54:- The environmental statement for each financial year ending 31st March in Form-V as is mandated to be submitted by the project proponent to the concerned State Pollution Control Board as prescribed under the Environment (Protection) Rules, 1986, as amended subsequently, shall also be put on the website of the company along with the status of compliance of EC conditions and shall also be sent to the respective Regional Offices of MOEF by e-mail.



महाराष्ट्र प्रदूषण नियंत्रण मंडळ

WELCOME CITY AND INDUSTRI...

[Applications](#) | [Dashboard](#) | [Change Password](#) | [Industry Documents](#) | [Logout](#)

### FORM V

(See Rule 14)  
Environmental Audit Report for the financial Year ending the 31st March 2022

#### Part A

##### Company Information

* Company Name	* Application UAN number	* Financial Year
<input type="text" value="M/s. CITY AND INDUSTRIAL DEVELOPMENT CORP"/>	<input type="text" value="MPCB-CONSENT-000093536"/>	<input type="text" value="April 2021 - March 2022"/>
* Address		
<input type="text" value="CIDCO Bhavan,CBD Belapur,Navi Mumbai"/>		
* Plot Number	* Taluka	* Village
<input type="text" value="Plot no. 2, Sector 6,"/>	<input type="text" value="Panvel"/>	<input type="text" value="Navi Mumbai"/>
* Capital Investment (In lakhs)	* Scale	
<input type="text" value="107674.00"/>	<input type="text" value="L.S.I"/>	
* City	* Pincode	
<input type="text" value="Raigad"/>	<input type="text"/>	
* Person Name	* Designation	
<input type="text"/>	<input type="text"/>	

## GENERAL CONDITIONS

Point 55:- The environmental clearance is being issued without prejudice to the action initiated under EP Act or any court case pending in the court of law and it does not mean that project proponent has not violated any environmental laws in the past and whatever decision under EP Act or of the Hon'ble court will be binding on the project proponent. Hence this clearance does not give immunity to the project proponent in the case filed against him, if any or action initiated under EP Act.

Noted



## GENERAL CONDITIONS

Point 56:- In case of submission of false document and non-compliance of stipulated conditions, Authority/ Environment Department will revoke or suspend the Environment clearance without any intimation and initiate appropriate legal action under Environmental Protection Act, 1986

For Info

## GENERAL CONDITIONS

Point 57:- The Environment department reserves the right to add any stringent condition or to revoke the clearance if conditions stipulated are not implemented to the satisfaction of the department or for that matter, for any other administrative reason

For Info

## GENERAL CONDITIONS

Point 58:- Validity of Environment Clearance: The environmental clearance accorded shall be valid as per EIA Notification, 2006, amended time to time.

For Info

## GENERAL CONDITIONS

Point 59:- In case of any deviation or alteration in the project proposed from those submitted to this department for clearance, a fresh reference should be made to the department to assess the adequacy of the condition(s) imposed and to incorporate additional environmental protection measures required, if any.

Not Applicable

## GENERAL CONDITIONS

Point 60:- The above stipulations would be enforced among others under the Water (Prevention and Control of Pollution) Act, 1974, the Air (Prevention and Control of Pollution) Act, 1981, the Environment (Protection) Act, 1986 and rules there under, Hazardous Wastes (Management and Handling) Rules, 1989 and its amendments, the public Liability Insurance Act, 1991 and its amendments.

For info

## GENERAL CONDITIONS

Point 61:- Any appeal against this Environment clearance shall lie with the National Green Tribunal (Western Zone Bench, Pune), New Administrative Building, 1st Floor, D - Wing, Opposite Council Hall, Pune, if preferred, within 30 days as prescribed under Section 16 of the National Green Tribunal Act, 2010.

For info

# Thank You