

Approved subject to condition mentioned in Amended Commencement Certificate issued by the office bearing Certificate no. CIDCO/NAINA/Panvel/Shivkar/BP-00321/ACC/2024/0483 dated 27 Feb 2024

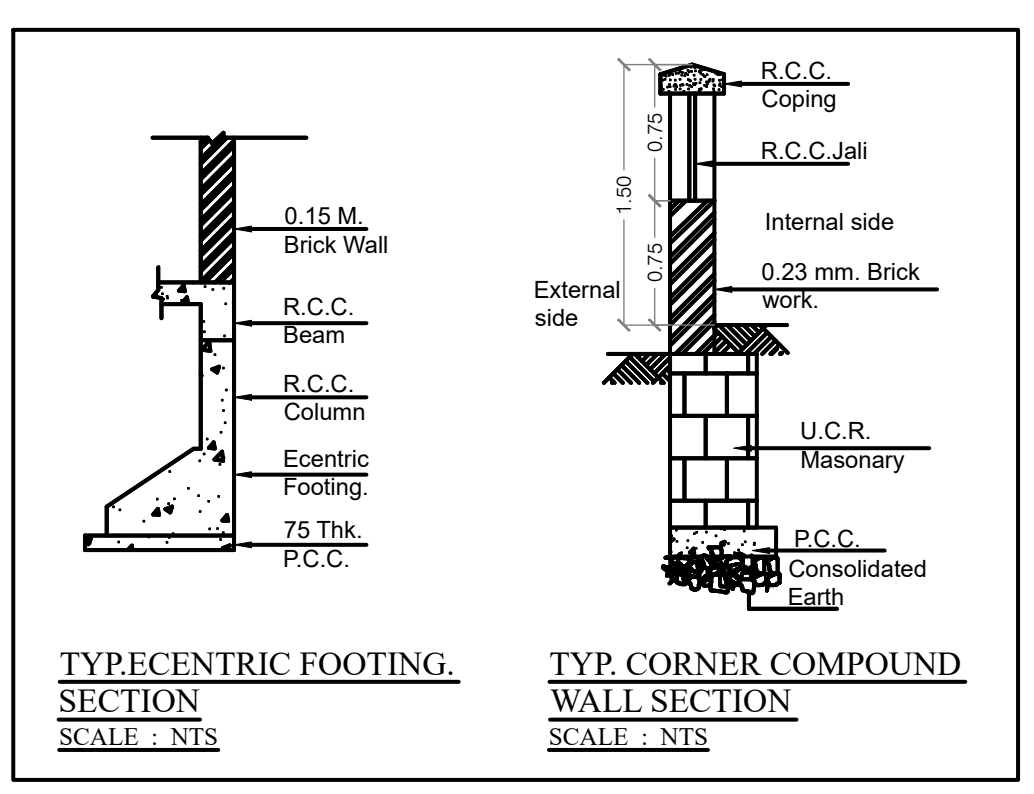

OVERHEAD WATER TANK CAPACITY CALCULATION

Building Number	Water Required (Liter) 50% OF U.G. TANK	Overhead water tank provision		
		Tank size (Meter)	Number of tank	Capacity (Liter)
(1)	(2)	(3)	(4)	(5)
1	17933	4.15 X 2.50 X 1.50	1	15500
		4.15 X 2.50 X 1.50	2	15500
		4.15 X 2.50 X 1.50	3	15500
Total	17933			46500

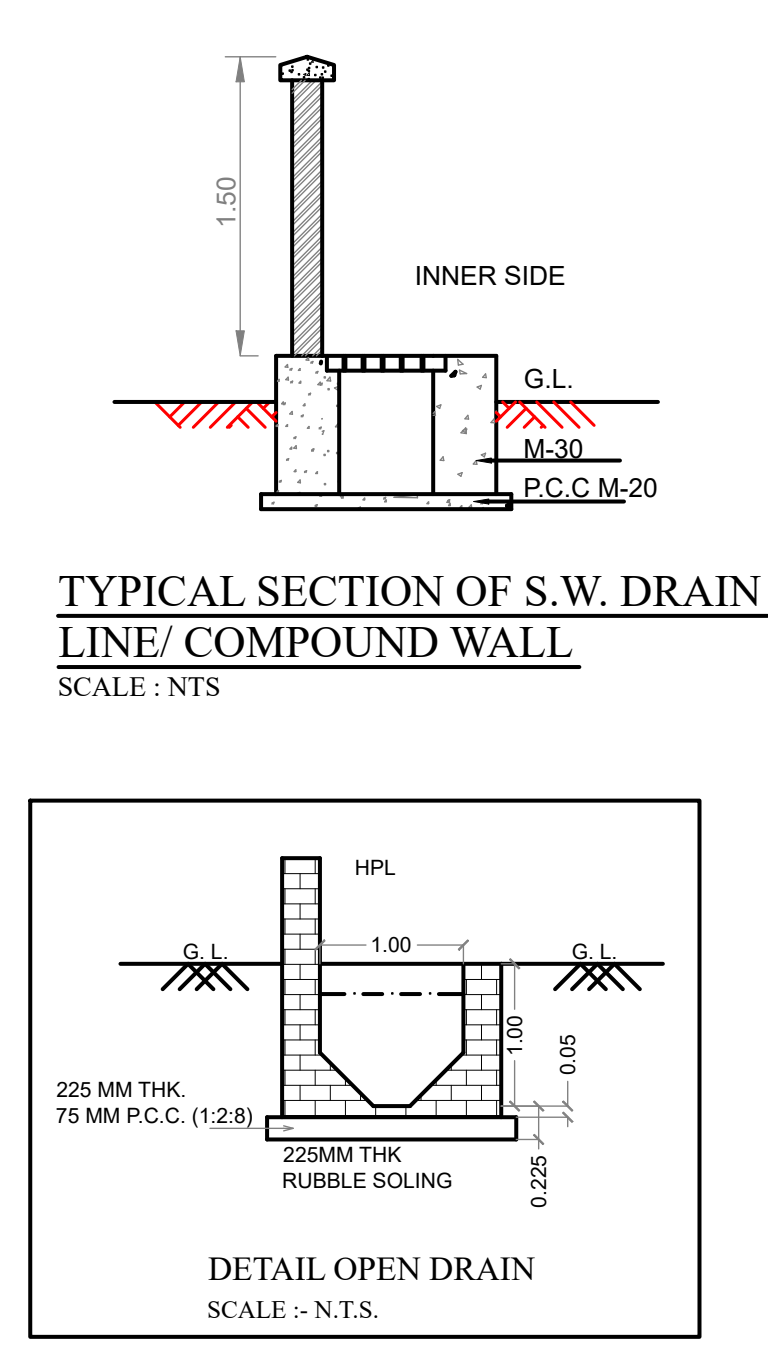
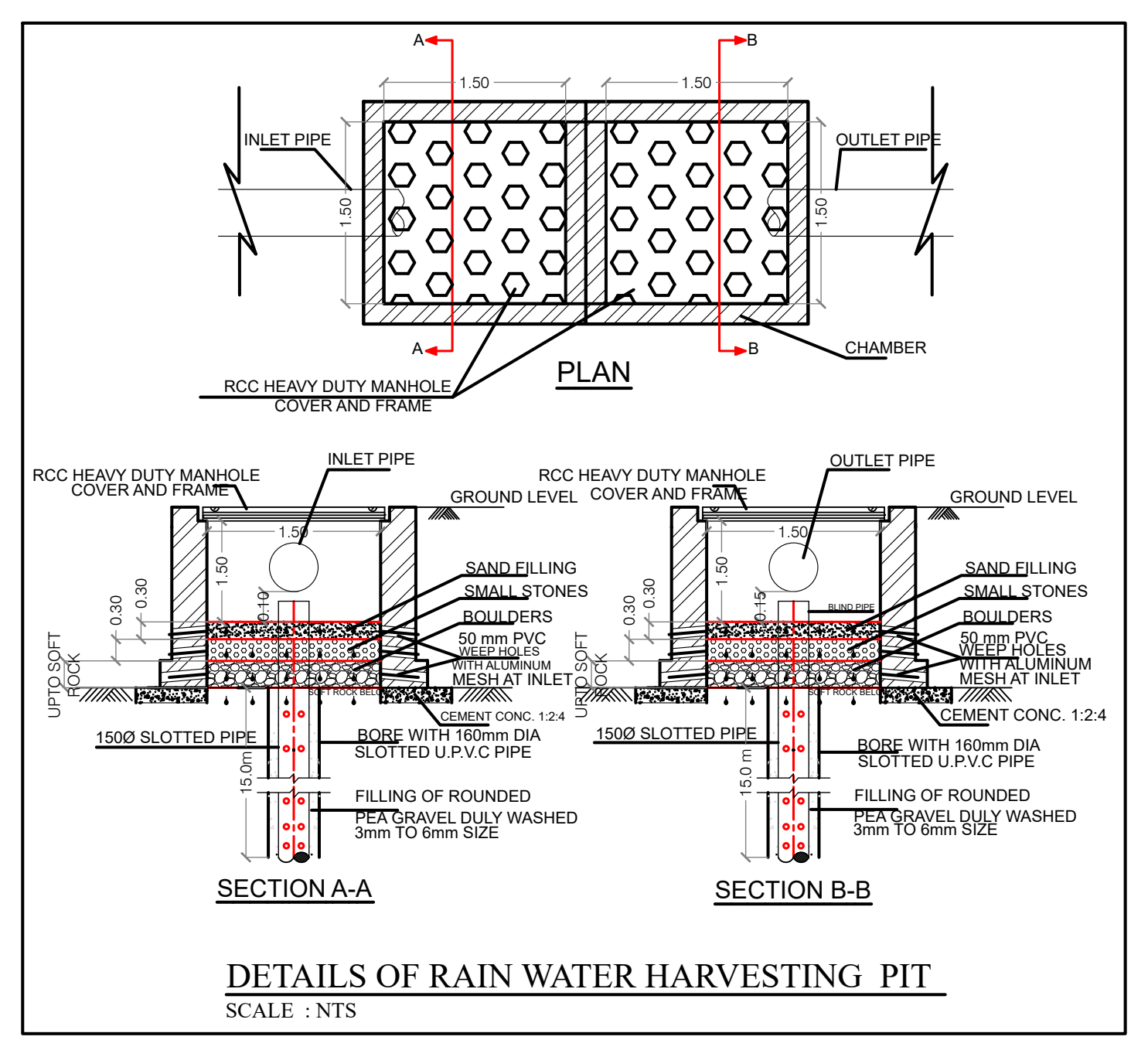
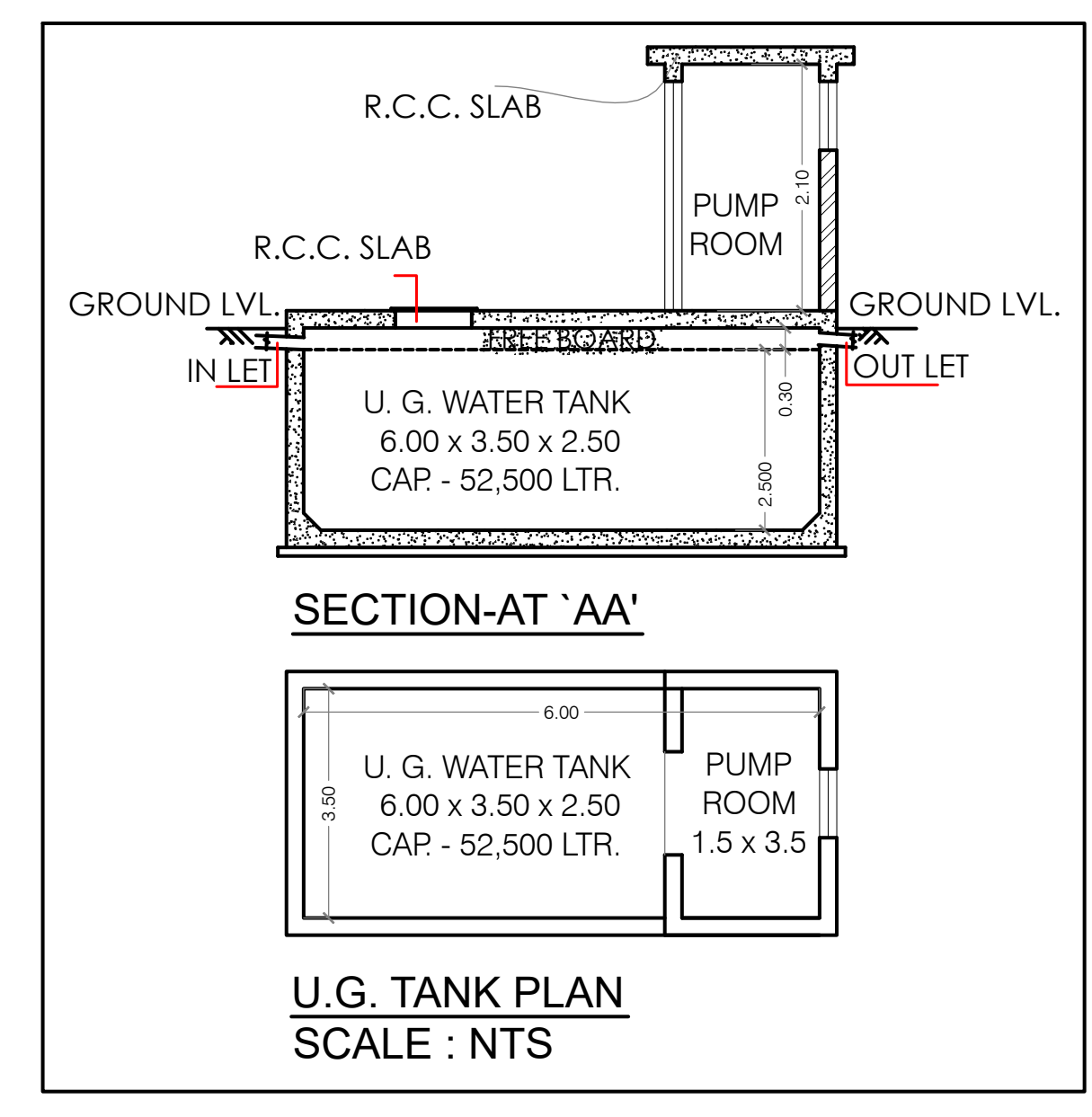

Water Storage Capacity Calculation (ACCORDING TO DCPR FOR DEVELOPMENT PLAN OF NAINA TABLE NO. 37.1)

Building Number	Total Number of Units	Addl. Toilet	Population	Water Requirement (In Liter)			Total	Tank Number	Size/ Dimension	Capacity (Liter)
				Add. Toilet	Population	Total				
1	2	3	(4) = (2) X 5	(5) = (3) X 180	(6) = (4) X 189	(7) = (5) + (6)	8	9	10	
1	37	5	185	900	34965	35865	1	6.00 x 3.50 x 2.50 + 0.30 FREE BOARD	52500	
Total	37	5	185	900	34965	35865	1		52500	

SEPTIC TANK REQUIREMENT (ACCORDING TO DCPR FOR DEVELOPMENT PLAN OF NAINA TABLE NO. 37.1)

Building Number	Number of Tenement	Population	Water Requirement					Flow to Sewer			Total Flow to Septic Tank (REQUIRED)	Septic Tank Provided	
			Flushing		Domestic		Total	Flushing -100%	Domestic -85%	Total			
			LPD	LPD	LPD	LPD							LPD
(1)	(2)	(3) = (2) X 5	(4)	(5) = (3) X (4)	(6)	(7) = (3) X (6)	(8) = (5) + (7)	(9) = (5) X 100%	(10) = (7) X 85%	(11) = (9) + (10)	(12)	(13)	
1	37	185	54	9990	135	24975	34965	9990	21229	31219	31219	6.00 x 3.50 x 2.50 + 0.30 FREE BOARD	46200
			ADD. TOILET	5	270	630	900	270	536	806	806	+ 0.30 FREE BOARD	
TOTAL						10260	25605	35865	10260	21764	32024	32024	

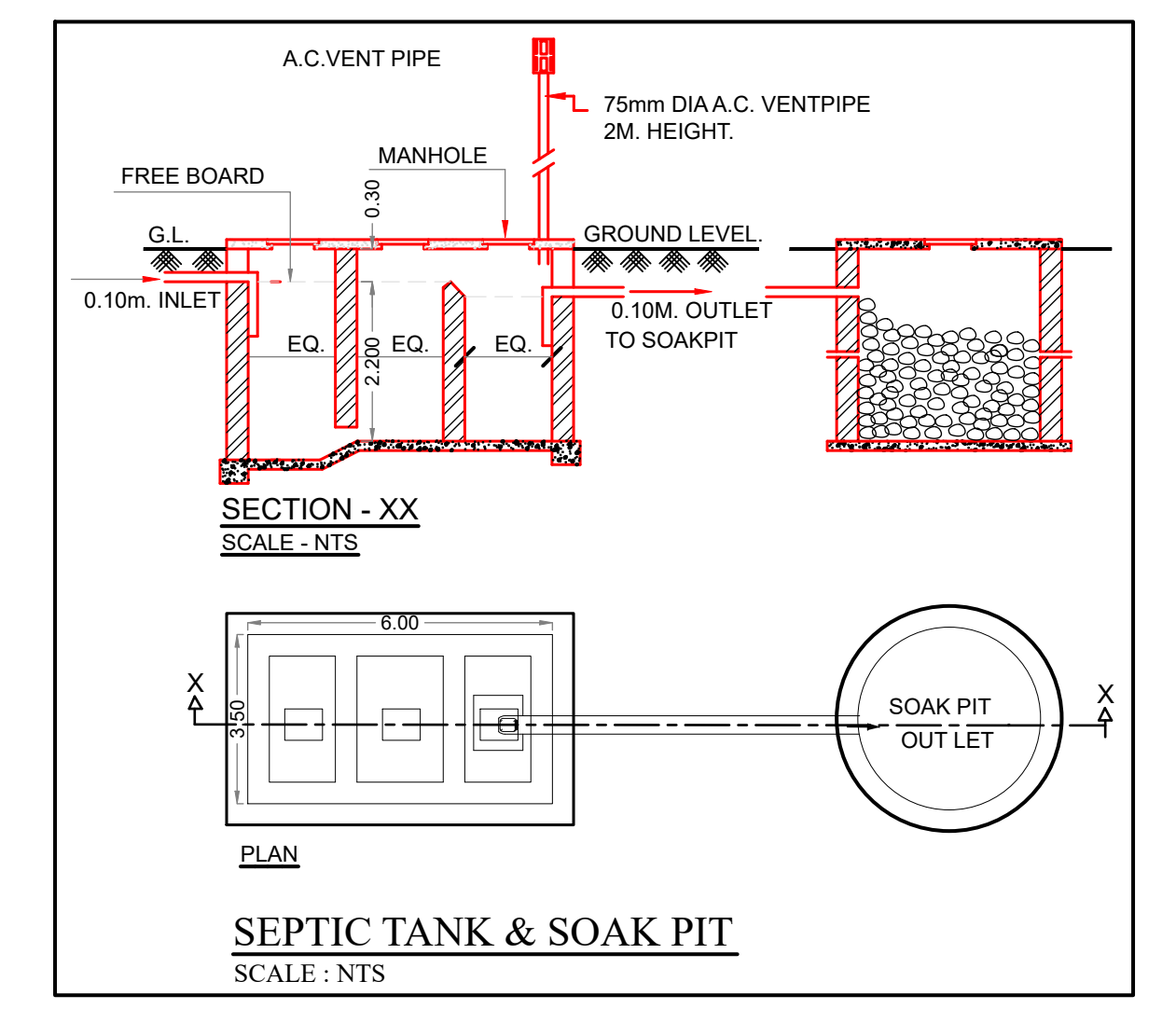
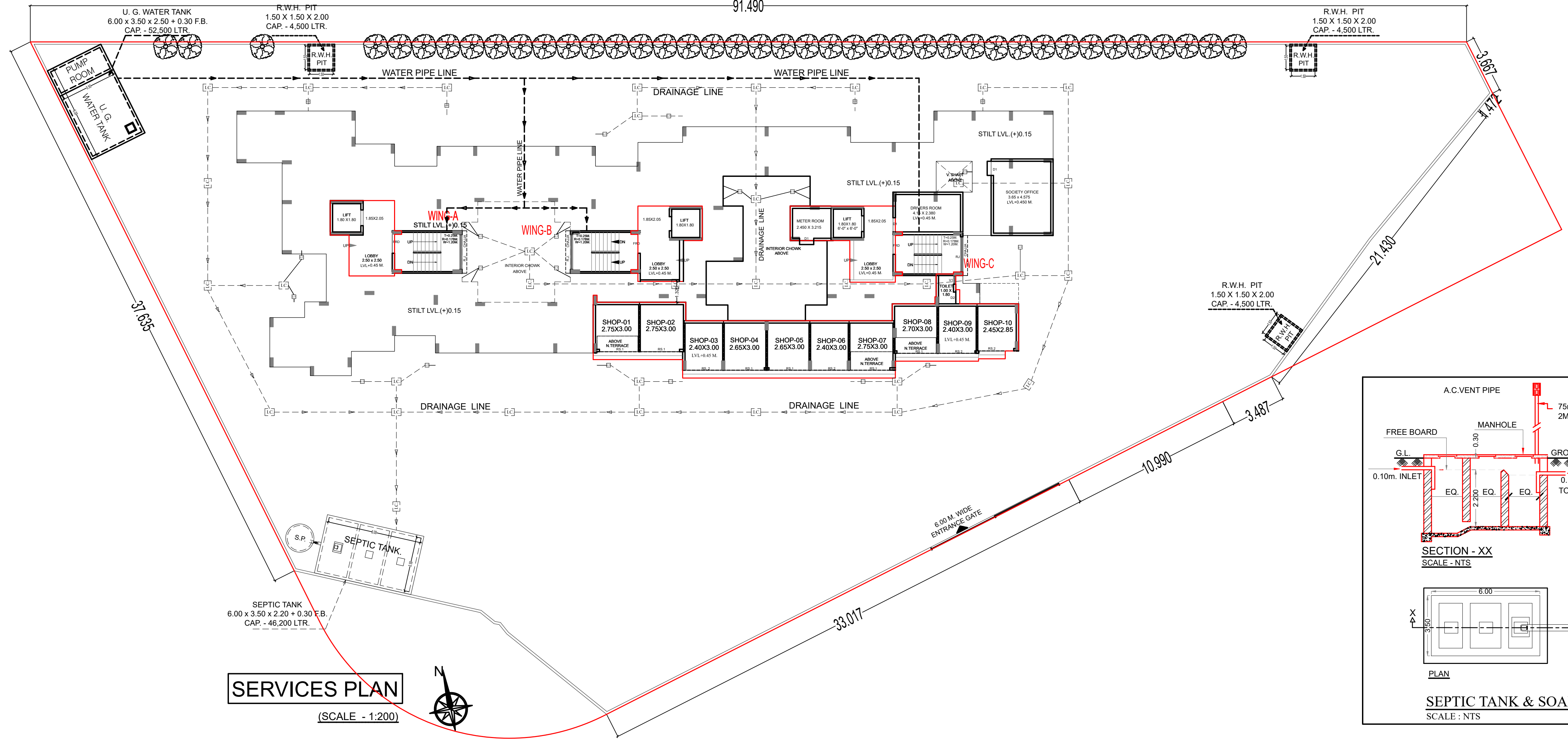
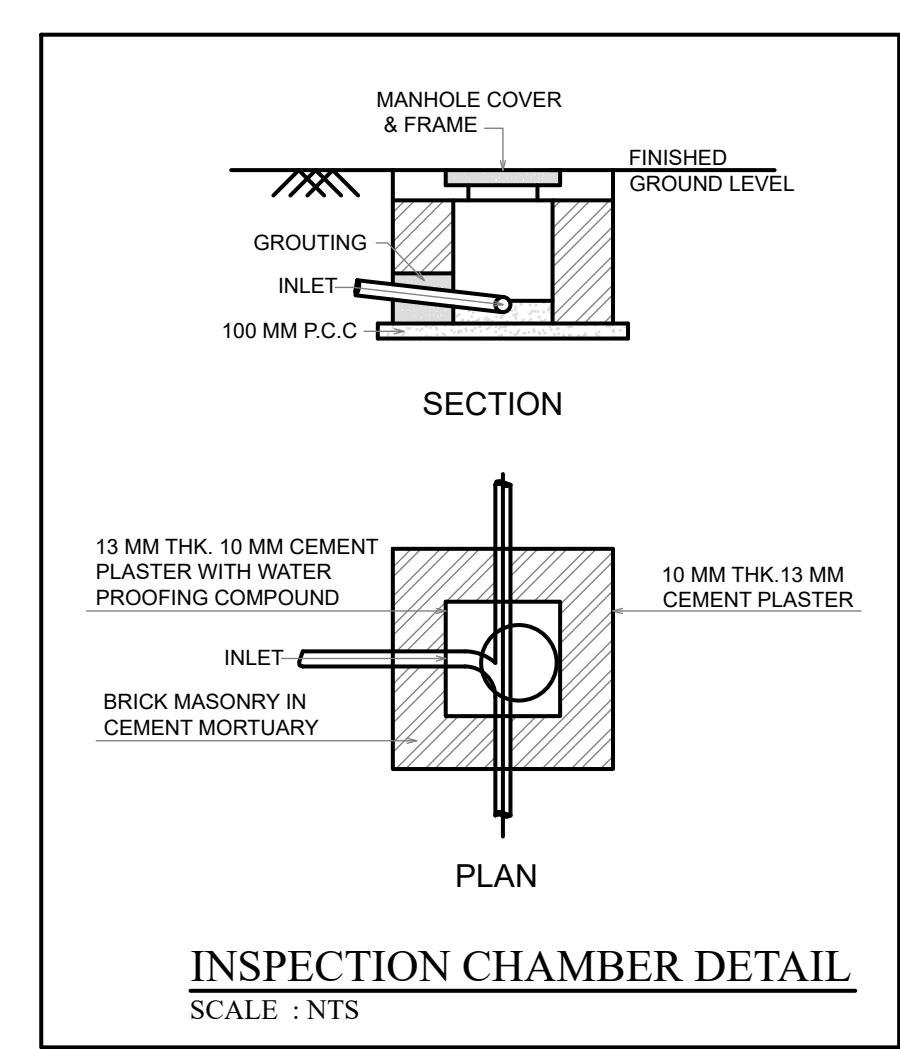

CERTIFICATE OF AREA

CERTIFIED THAT THE PLOT UNDER REFERENCE WAS SURVEYED BY ME ON 10-12-2014 AND THE DIMENSIONS SIDES ETC OF PLOT STATED ON ON PLAN ARE AS MEASURED ON SITE AND THE AREA SO WORKED OUT TALLIES WITH THE AREA STATED IN DOCUMENT OF OWNERSHIP/T.P. SCHEME RECORDS / LAND RECORDS DEPARTMENT/CITY SURVEY RECORDS.

MR. Ruzan Shabbir Shaikh AR. SHEETAL NEMANE

NAME OF THE OWNER SIGNATURE OF OWNER SIGNATURE OF ARCHITECT

PROJECT

PROPOSED RESIDENTIAL BUILDING ON GUT NO. 320, AT - SHIVKAR, TALUKA - PANVEL, DIST- RAIGAD

FORM OF CERTIFICATE

(SHEETAL ARCHITECTS) HAVE BEEN EMPLOYED BY THE APPLICANT AS HIS ARCHITECT. I HAVE EXAMINED THE BOUNDARIES AND THE AREA OF THE PLOT AND I DO HEREBY CERTIFY THAT I HAVE PERSONALLY VERIFIED AND CHECKED ALL THE STATEMENTS MADE BY THE APPLICANT WHO IS THE OWNER / LESSEE IN POSSESSION OF THE PLOTS AS IN THE ABOVE FORM AND FOUND THEM TO BE CORRECT.

ADDRESS:
ADD: Office No. 117, Raheja Arcade, sector 11, CBD Belapur, NAVI MUMBAI-400614. shheetal@shheetal.com Office No: 02241279232

AR. SHEETAL NEMANE SIGNATURE OF ARCHITECT

NAME & SIGN. OF ARCHITECT

AR. SHEETAL NEMANE

SANJOG	1:100/1:200/1:500	30.01.2024	
DRAWN BY	SCALE	DATE	DRAWING NO.

Sheetal Architects

ADD: Office No. 12, Raheja Arcade, sector 11, CBD Belapur, NAVI MUMBAI-400614. Office No: 02241279232

Approved subject to condition mentioned in Amended Commencement Certificate issued by the office bearing Certificate No. CIDCO/NAINA/Parvel/Shivkar/BP-00321/ACC/2024/0483 dated 27 Feb 2024

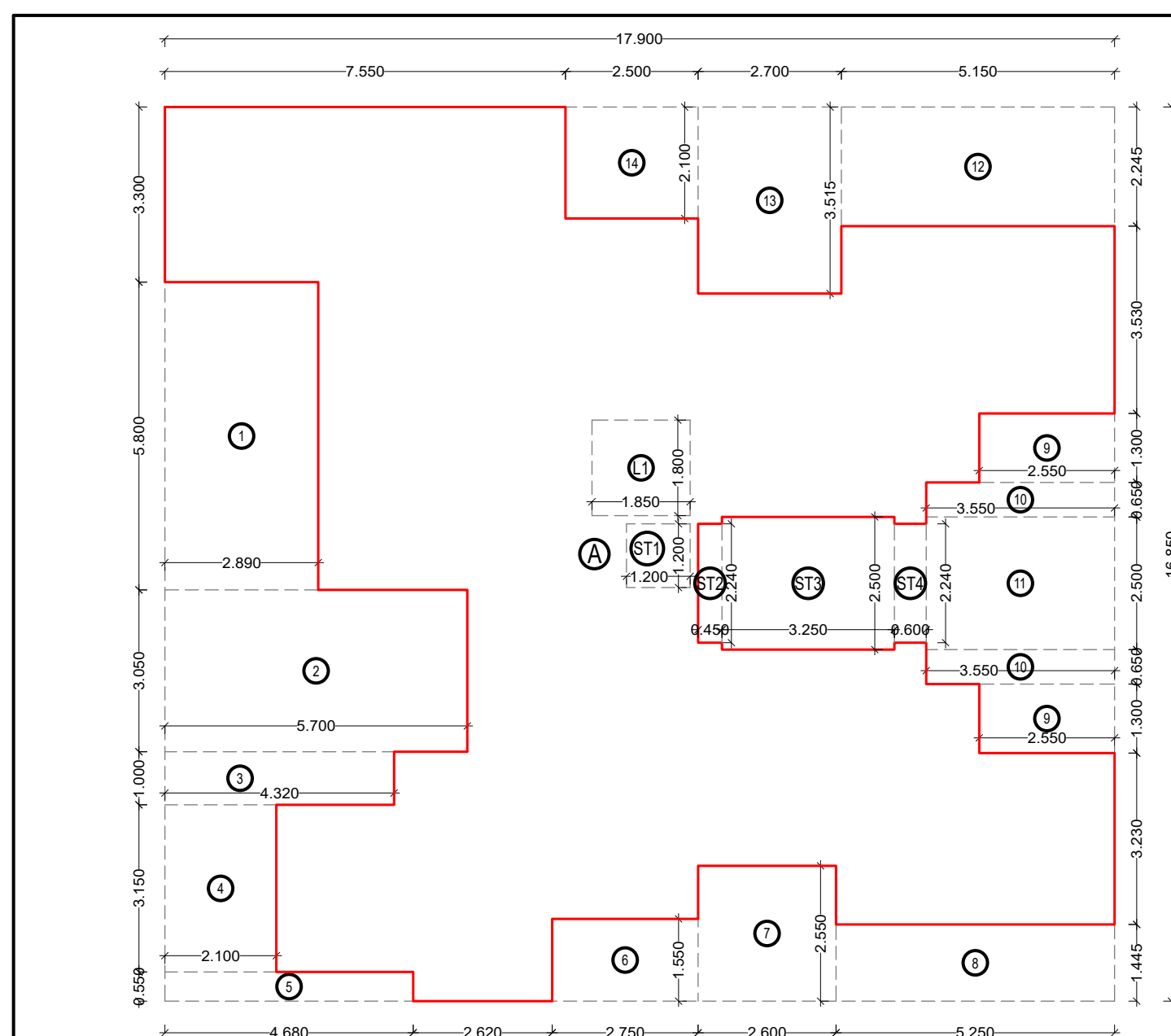

THIRD FLOOR				
BLOCK DESCRIPTION	NUMBER OF DEDUCTION	LENGTH (M)	HEIGHT (M)	AREA (SQM)
1	3	17.900	16.800	301.615
SUBTOTAL - A				301.615
DEDUCTION				
1	1	2.900	3.900	16.762
2	1	5.700	3.050	17.385
3	1	4.320	1.000	4.320
4	1	2.100	3.150	6.615
5	1	4.680	0.550	2.574
6	1	2.750	1.550	4.263
7	1	2.600	2.550	6.630
8	1	5.750	1.445	7.566
9	2	2.550	1.300	6.630
10	2	3.550	0.650	4.615
11	1	1.850	2.550	4.727
12	1	5.150	2.245	11.562
13	1	2.700	3.515	9.491
14	1	2.500	2.100	5.250
15	1	1.850	1.800	3.330
S13	1	1.200	1.200	1.440
S12	1	0.450	2.240	1.008
S13	1	1.250	2.550	3.188
S14	1	0.600	2.240	1.344
SUBTOTAL - B				127.804
TOTAL BUILT UP AREA AT THIRD FLOOR				173.811

SCHEDULE OF DOOR & WINDOWS				
TYPE	WIDTH (Meter)	X	HEIGHT (Meter)	DISCUSSION
FRD	1.200	X	2.100	METAL FIRE RATED DOOR
D	1.000	X	2.100	T.W. FRAMED PANELLED DOOR
D1	0.900	X	2.100	T.W. FRAMED PANELLED DOOR
D2	0.750	X	2.100	T.W. FRAMED PANELLED DOOR
W	2.500	X	2.100	ALLU. FRAMED SLIDING WIN.
W1	2.300	X	2.100	ALLU. FRAMED SLIDING WIN.
W2	2.200	X	2.100	ALLU. FRAMED SLIDING WIN.
W3	2.250	X	2.100	ALLU. FRAMED SLIDING WIN.
W4	2.350	X	2.100	ALLU. FRAMED SLIDING WIN.
W5	1.840	X	2.100	ALLU. FRAMED SLIDING WIN.
W6	2.180	X	2.100	ALLU. FRAMED SLIDING WIN.
W7	2.700	X	2.100	ALLU. FRAMED SLIDING WIN.
W8	2.100	X	2.100	ALLU. FRAMED SLIDING WIN.
W9	2.450	X	2.100	ALLU. FRAMED SLIDING WIN.
V	0.600	X	0.900	LOUVER WINDOW.
V1	0.550	X	0.900	LOUVER WINDOW.
V2	0.450	X	0.900	LOUVER WINDOW.
RJ	1.200	X	1.350	R.C.C. JHALL
RS1	2.500	X	2.400	ROLLING SHUTTER
RS2	2.240	X	2.400	ROLLING SHUTTER

LIGHT AND VENTILATION STATEMENT (WING - A)						
SR. NO.	FLAT NO.	ROOM	SIZE OF ROOM	PROPOSED AREA FOR HABITABLE ROOM WITH ONE DIMENSION OF 3.0 M OR MORE WITH ONE WINDOW	VENTILATION WINDOW AREA	MIN. VENTILATION WINDOW AREA
1	101 TO 101	LIVING	2.200 X 3.400	7.480	1.150	0.767
2	101 TO 101	KITCHEN	2.400 X 2.700	6.480	0.750	0.500
3	101 TO 101	BED ROOM	2.400 X 3.000	7.200	0.750	0.500
4	101 TO 101	BATH	1.800 X 1.200	2.160	0.450	0.300
5	101 TO 101	TOILET	1.200 X 1.200	1.440	0.300	0.200

LIGHT AND VENTILATION STATEMENT (WING - B)						
SR. NO.	FLAT NO.	ROOM	SIZE OF ROOM	PROPOSED AREA FOR HABITABLE ROOM WITH ONE DIMENSION OF 3.0 M OR MORE WITH ONE WINDOW	VENTILATION WINDOW AREA	MIN. VENTILATION WINDOW AREA
1	101 TO 201	LIVING	2.200 X 3.400	7.480	1.150	0.767
2	101 TO 201	KITCHEN	2.400 X 2.700	6.480	0.750	0.500
3	101 TO 201	BED ROOM	2.400 X 3.000	7.200	0.750	0.500
4	101 TO 201	BATH	1.800 X 1.200	2.160	0.450	0.300
5	101 TO 201	TOILET	1.200 X 1.200	1.440	0.300	0.200

LIGHT AND VENTILATION STATEMENT (WING - C)						
SR. NO.	FLAT NO.	ROOM	SIZE OF ROOM	PROPOSED AREA FOR HABITABLE ROOM WITH ONE DIMENSION OF 3.0 M OR MORE WITH ONE WINDOW	VENTILATION WINDOW AREA	MIN. VENTILATION WINDOW AREA
1	101 TO 301	LIVING	2.200 X 3.400	7.480	1.150	0.767
2	101 TO 301	KITCHEN	2.400 X 2.700	6.480	0.750	0.500
3	101 TO 301	BED ROOM	2.400 X 3.000	7.200	0.750	0.500
4	101 TO 301	BATH	1.800 X 1.200	2.160	0.450	0.300
5	101 TO 301	TOILET	1.200 X 1.200	1.440	0.300	0.200

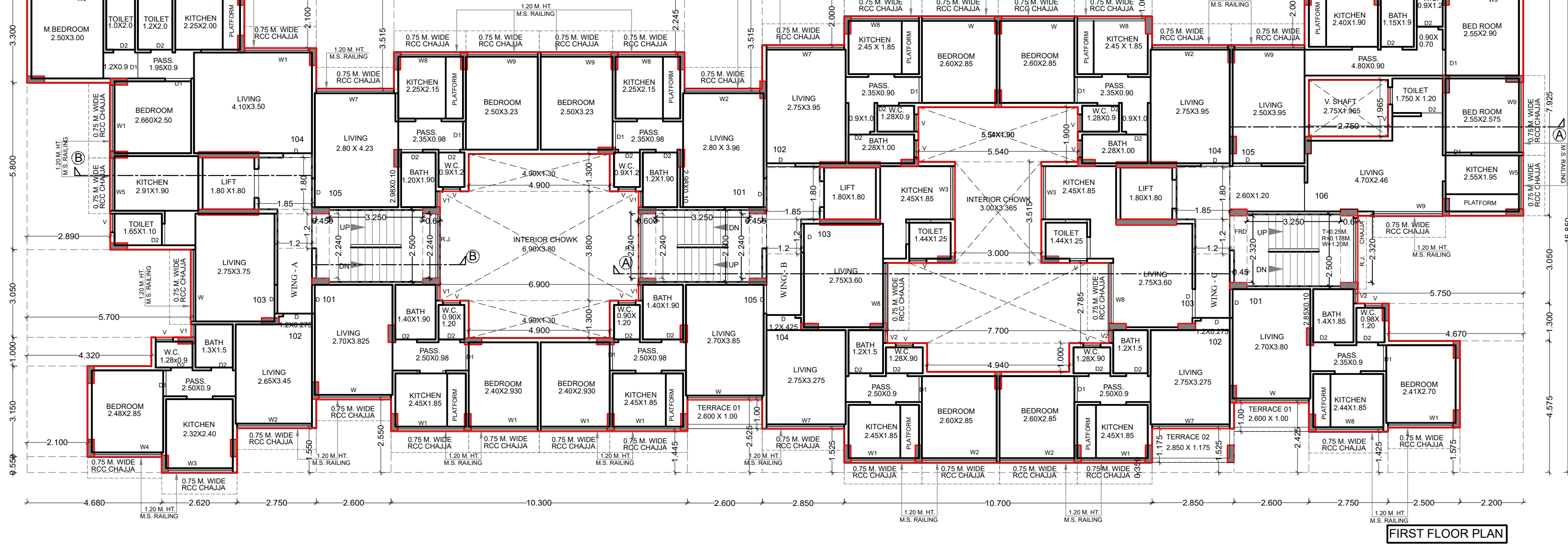
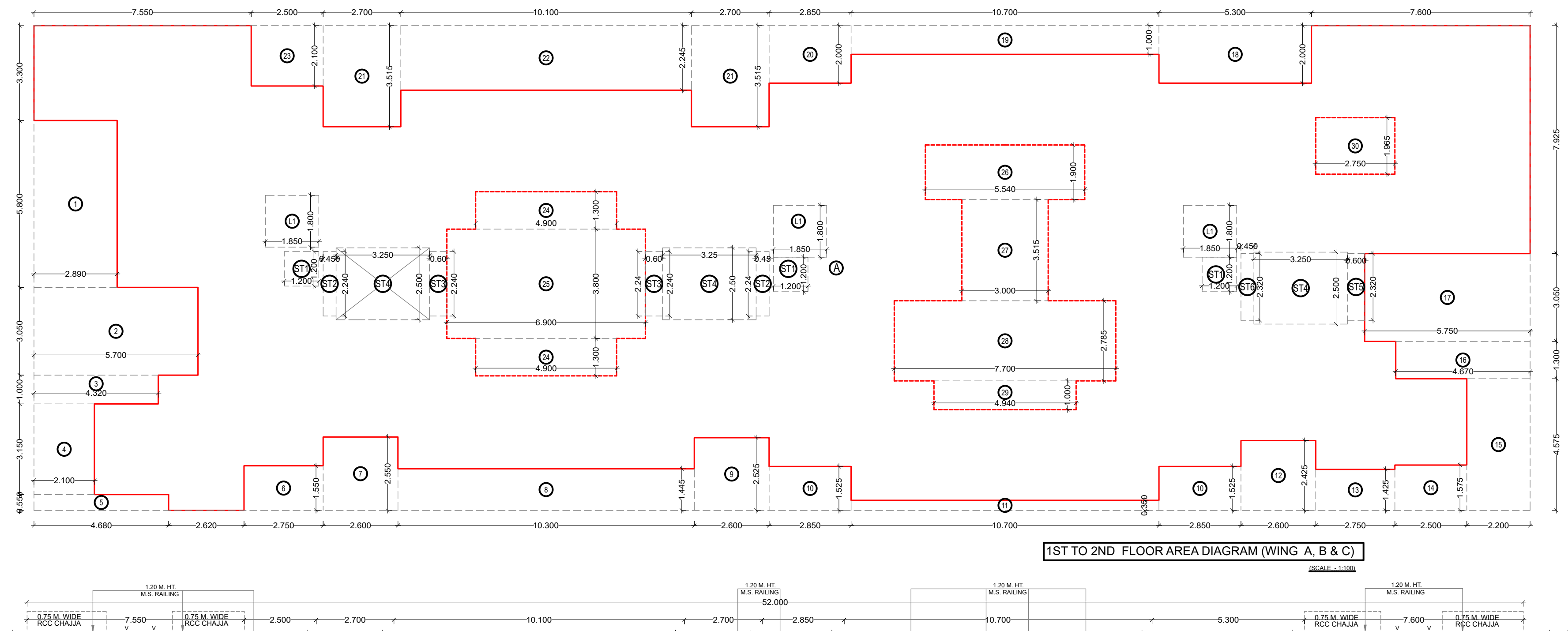
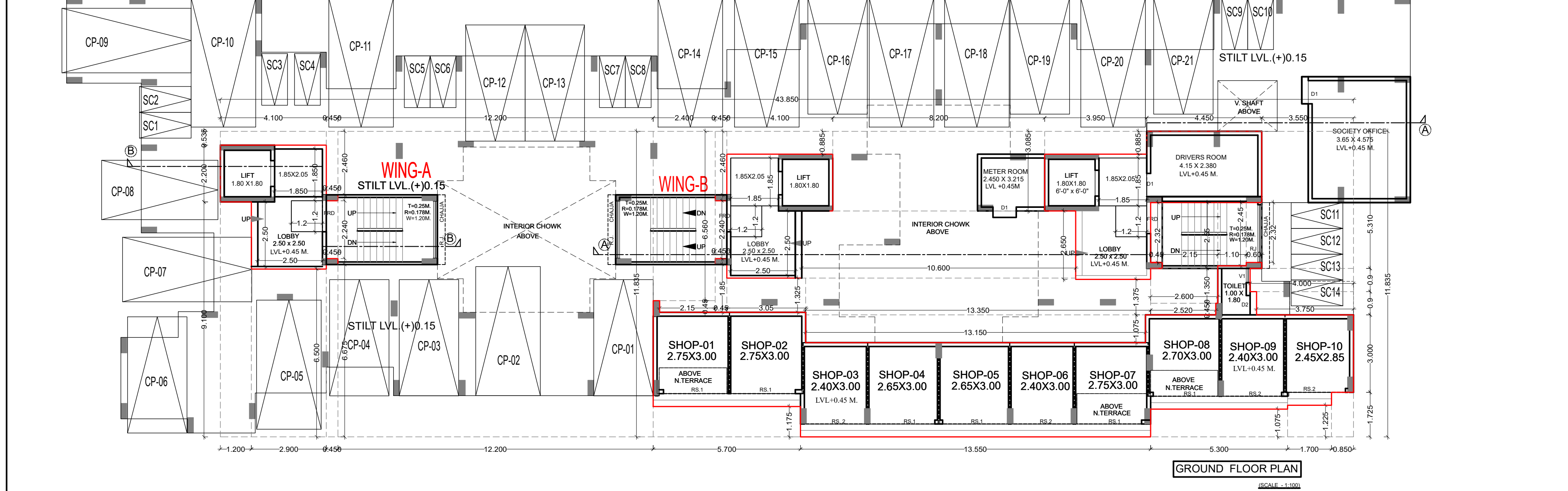
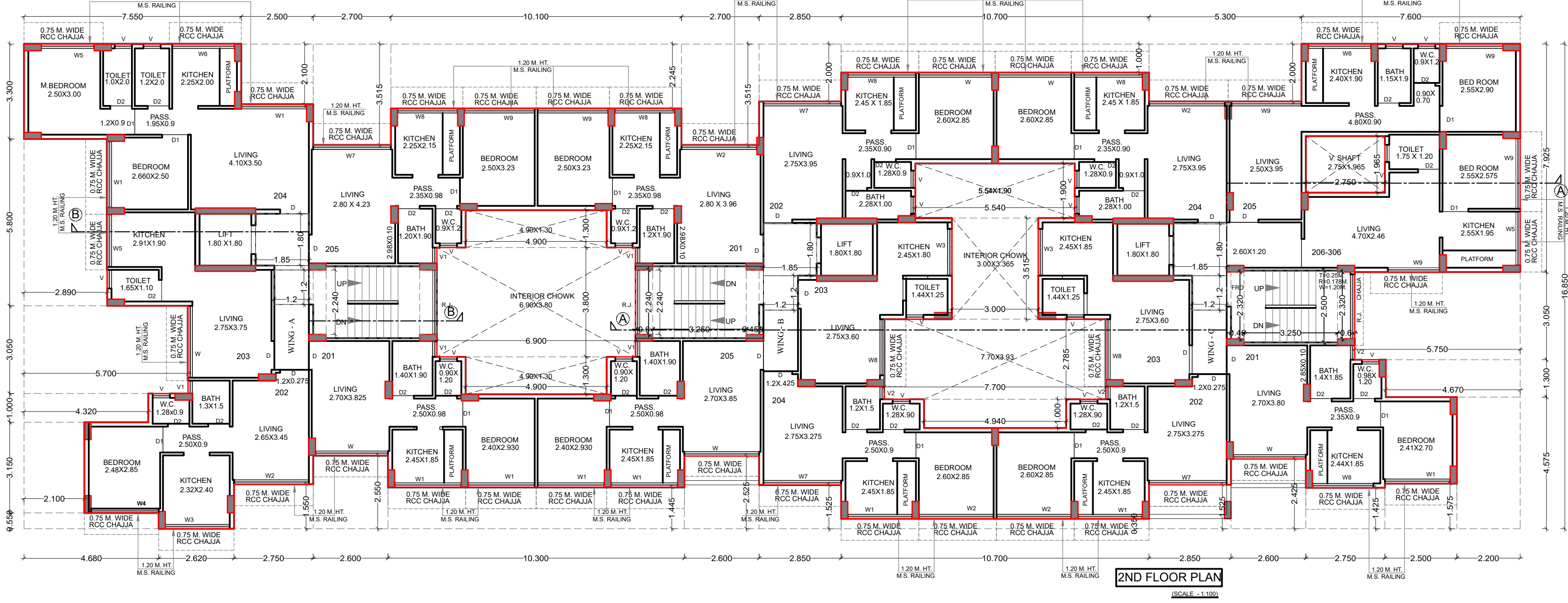
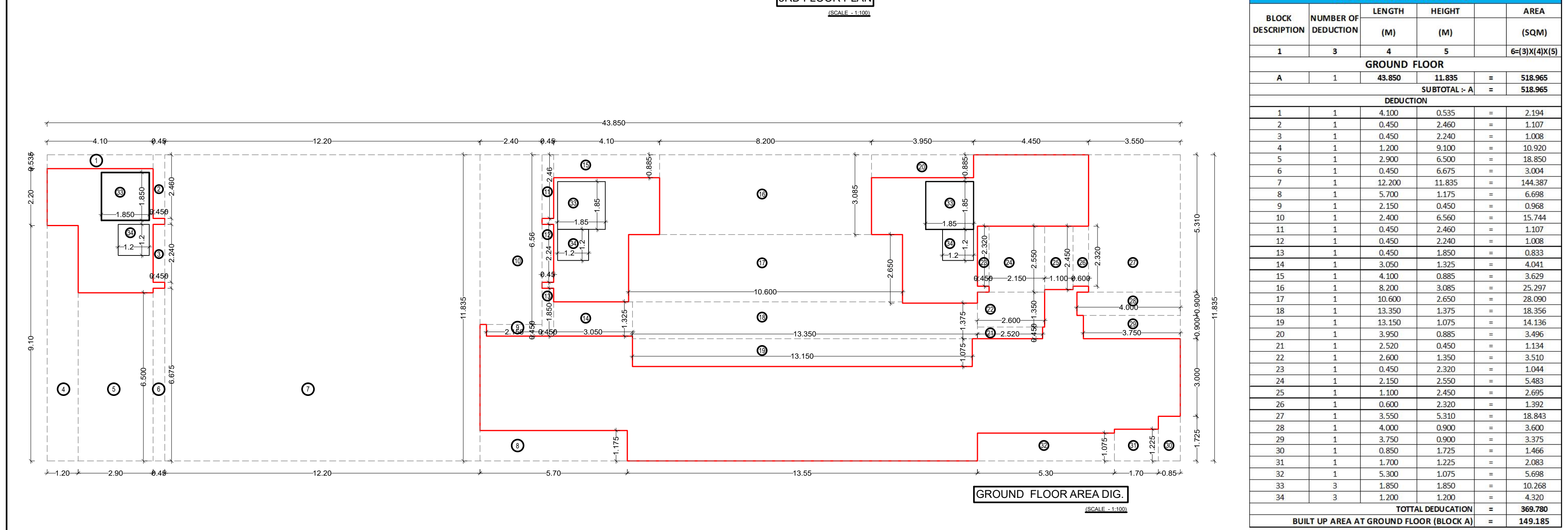
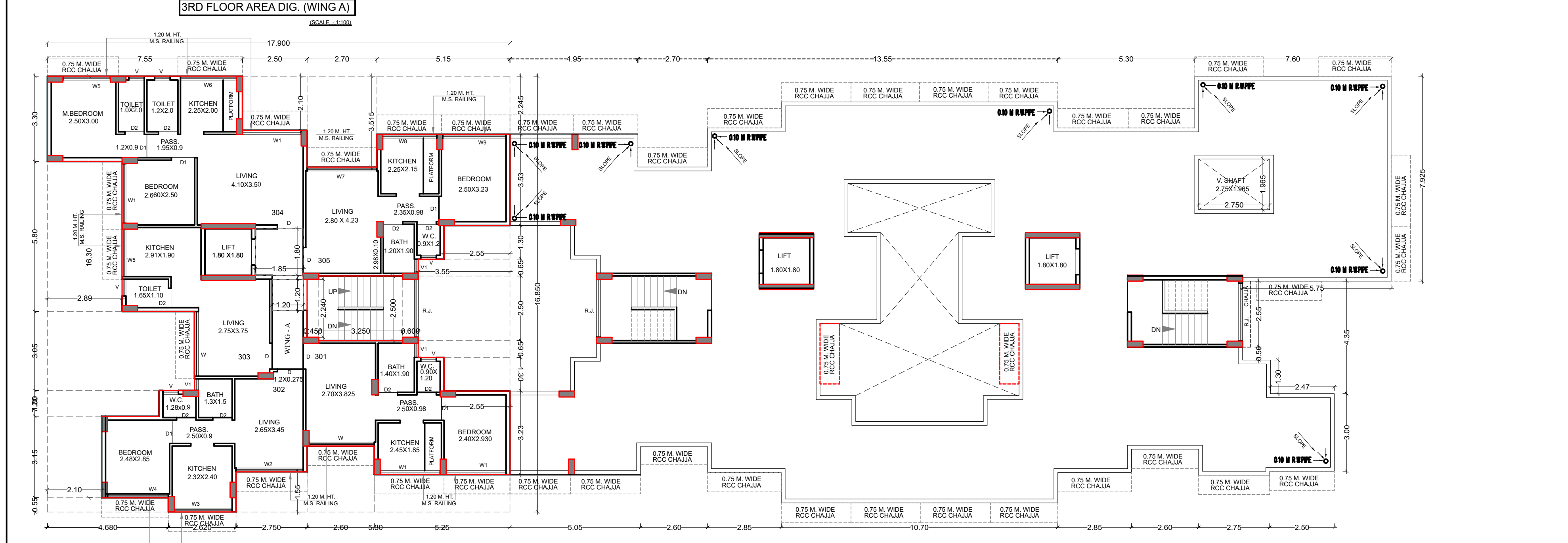

1ST & 2ND FLOOR AREA CALCULATION				
BLOCK DESCRIPTION	NUMBER OF DEDUCTION	LENGTH (M)	HEIGHT (M)	AREA (SQM)
1	3	52.000	16.800	876.200
SUBTOTAL - A				876.200
DEDUCTION				
1	1	2.800	5.800	16.262
2	1	5.700	3.050	17.385
3	1	4.320	1.000	4.320
4	1	2.100	3.150	6.615
5	1	4.680	0.550	2.574
6	1	2.750	1.550	4.263
7	1	2.600	2.550	6.630
8	1	10.300	1.445	14.884
9	1	2.600	2.525	6.565
10	2	2.850	1.525	8.691
11	1	10.700	0.350	3.745
12	1	2.600	2.425	6.305
13	1	2.750	1.425	3.919
14	1	2.500	1.575	3.938
15	1	2.200	4.575	10.065
16	1	4.670	1.300	6.071
17	1	5.750	1.000	5.750
18	1	5.300	2.000	10.600
19	1	10.700	1.000	10.700
20	1	2.854	2.803	5.717
21	2	2.700	3.515	18.981
22	1	10.100	2.245	22.698
23	1	2.500	2.100	5.250
24	2	4.500	1.300	11.700
25	1	6.900	3.800	26.220
26	1	5.540	1.900	10.526
27	1	3.000	2.545	7.635
28	1	7.700	2.285	17.485
29	1	4.940	1.000	4.940
30	1	2.750	1.965	5.404
31	1	2.750	1.425	3.919
S13	3	1.200	1.200	4.320
S12	2	0.450	2.240	2.016
S13	3	3.250	2.200	24.375
S14	1	0.600	2.240	1.344
S15	1	0.450	2.240	1.008
SUBTOTAL - B				351.919
PERMISSIBLE TERRACE AREA @ 1st FLOOR				104.876
PROPOSED TERRACE AREA @ 1st FLOOR				8.549
TOTAL				5.200
PROPOSED TERRACE AREA @ 1st FLOOR				8.549

MR. Ruzan Shabbir Shah AR. SHEETAL NEMANE
 NAME OF THE OWNER SIGNATURE OF OWNER AR. SHEETAL NEMANE SIGNATURE OF ARCHITECT
 PROJECT PROPOSED RESIDENTIAL BUILDING ON GUT NO. 302 AT - SHIVKAR, TALUKA - PAVNAR, DIST. RANGAD
 NAME & SIGN. OF ARCHITECT
 AR. SHEETAL NEMANE
 SANJOG SCALE 1:100 DATE 30.01.2024 DRAWING NO.
 Sheetal Architects ADD Office No. 12 Ranajiv Arcade, sector 11, CBD Belapur, NAVI MUMBAI-400614. Office No. 0224 1273232

Approved subject to condition mentioned in Amended Commencement Certificate issued by the office bearing Certificate no. CIDCO/NAINA/Panvel/ Shivkar/BP-00321/ACC/2024/0483 dated 27 Feb 2024

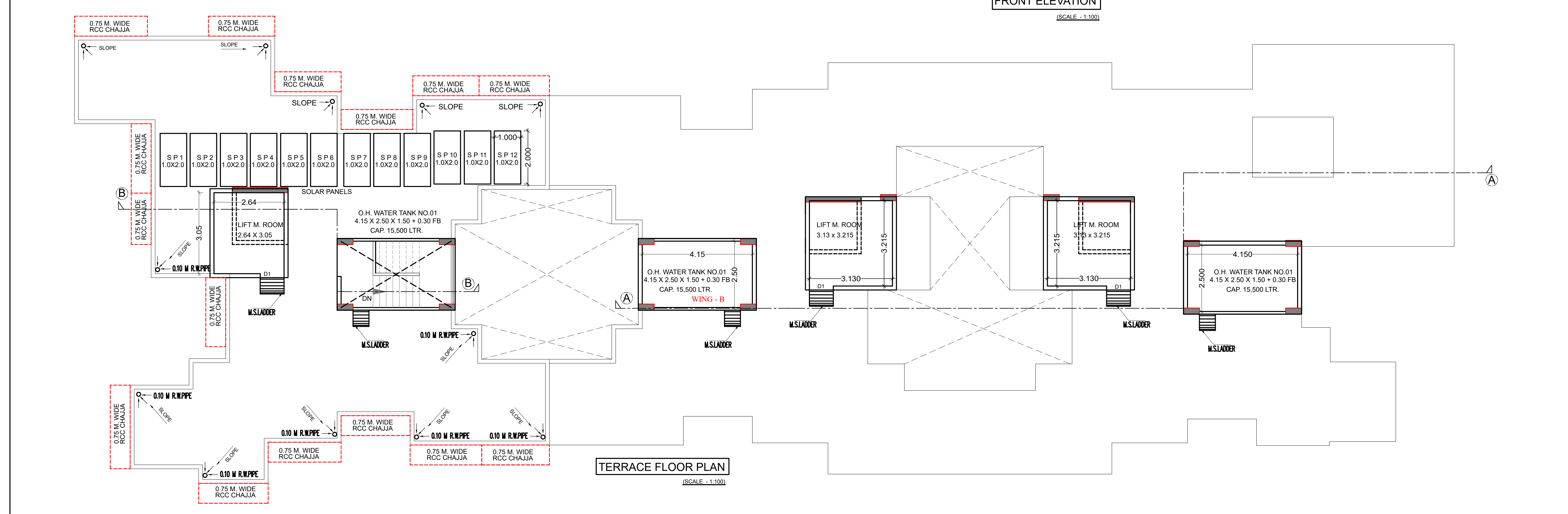
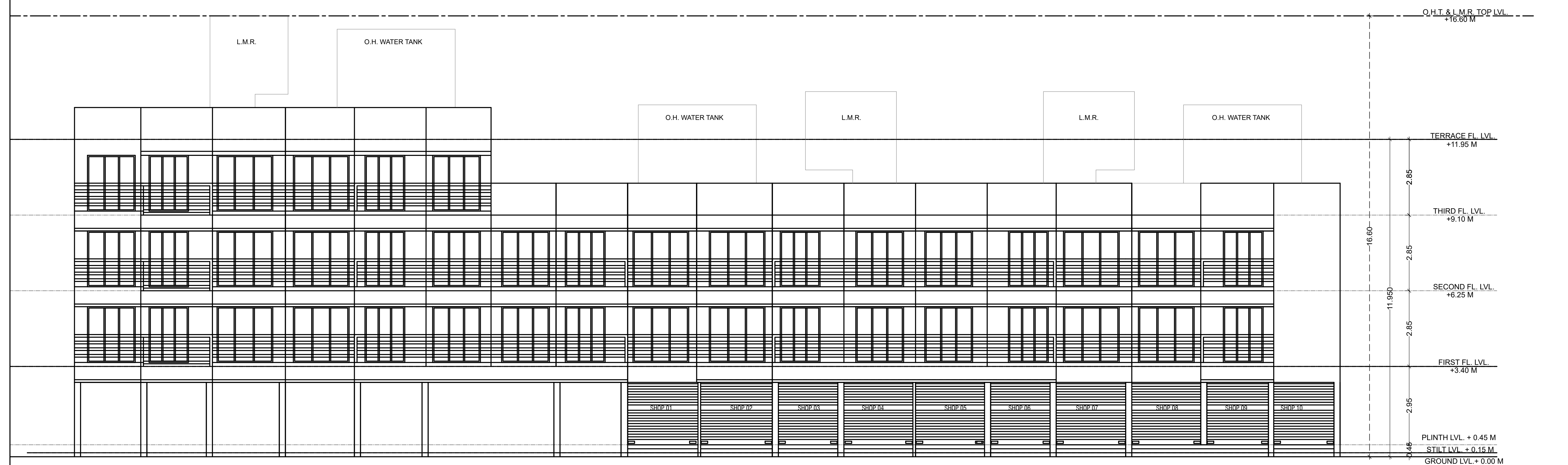
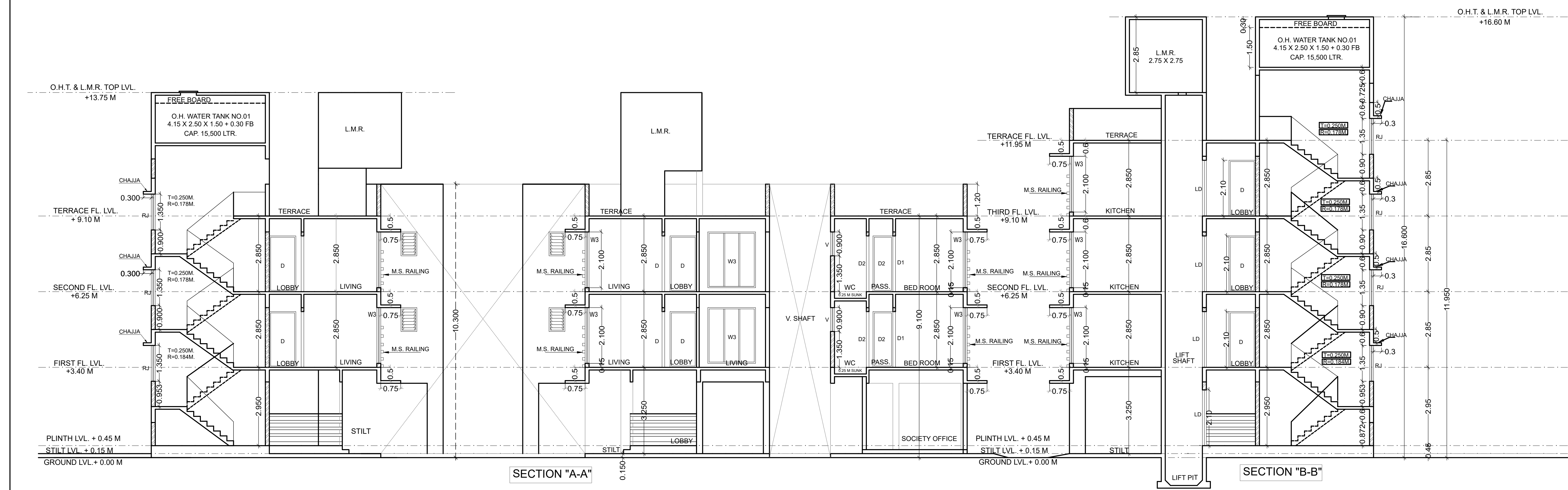

MR. Ruzan Shabbir Shaikh	AR. SHEETAL NEMANE		
NAME OF THE OWNER SIGNATURE OF OWNER	AR. SHEETAL NEMANE SIGNATURE OF ARCHITECT		
PROJECT			
PROPOSED RESIDENTIAL BUILDING ON GUT NO. 320, AT - SHIVKAR, TALUKA - PANVEL, DIST- RAIGAD			
NAME & SIGN. OF ARCHITECT			
AR. SHEETAL NEMANE			
SANJOG	1:100	30.01.2024	
DRAWN BY	SCALE	DATE	DRAWING NO.
Sheetal Architects ADD Office No. 12, Raheja Arcade, sector 11, CBD Belapur, NAVI MUMBAI-400614. Office No. 02241279232			